



my point of view



Leica Nature Observation

Binoculars, Rangefinders and Spotting Scopes



Leica Camera AG / Oskar-Barnack-Straße 11 / D-35606 Solms
Telephone +49(0)6442-208-0 / Fax +49(0)6442-208-333
leica-camera.com

Heine/Lenz/Zizka 07/07 / ADX / B







See more It is our eyes that guide us through the world, shaping our perception of our surroundings and all we encounter. We only have to watch shy animals, however, to realize that our natural power of vision sometimes lets us down. For a whole century, Leica has been meeting the challenge of making optical instruments to satisfy the high expectations of birdwatchers, for example. Our innovative range for sport optics, comprising binoculars, scopes and laser rangefinders, extends the natural limits of visibility by reaching further into the distance or picking up more detail when the available light is too weak for the human eye. All these instruments feature unmistakable Leica quality and unbeatable optical performance. As multifaceted as their applications, so too are the methods used to create sports optics products that display images rich in contrast and with outstanding color rendition. Glass containing fluorite or those with corrected spectral dispersion, aspherical and achromatic lenses, as well as modern multi-layer coatings like HDC™ and HighLux-System HLS™ ensure unforgettable visual experiences.

New ideas for even better visibility **Leica represents innovation. Our own outstanding achievements in terms of lenses and mechanics are being continuously monitored and the standards set even higher. Which is why Leica binoculars and spotting scopes**

Excellent image quality – even in awkward light conditions Stray or false light can significantly reduce the viewing experience. To eliminate this effectively, Leica is taking a great number of steps which, in awkward side-lighting and backlighting situations in particular, ensure a high-resolution, clear image without any reduction in contrast or constraints due to milky fogging. Specially developed software simulation allows stray light to be seen during development stage. Consequently, thanks to an optimized housing shape, improved light-absorbing paint, apertures and stray light traps, the construction of the new HD and APO models have been optimized to such a degree that stray light is (almost) no longer of any significance. Because after all, you cannot select the position of the sun when you are observing nature.

Consistently smooth focusing – whatever the temperature The mechanics for the Ultravid HD focusing have been further refined. As a result, focusing is even smoother and remains free of play across the entire range. Optimized material pairings and gliding discs made from extremely tough, high-performance plastic are used. In cold conditions, the conventional greased focusing mechanisms sometimes only work with difficulty, and at higher temperatures they move too freely. Furthermore, these focusing mechanisms can feel “sticky”, and at higher temperatures there is even the danger that grease can escape and run on the lens. With the optimized Leica focus, these risks have been eliminated. In the new Ultravid-HD models, it works practically without any lubricants. So even in extreme temperatures, it is always fully functional – with a constantly optimum degree of smoothness.

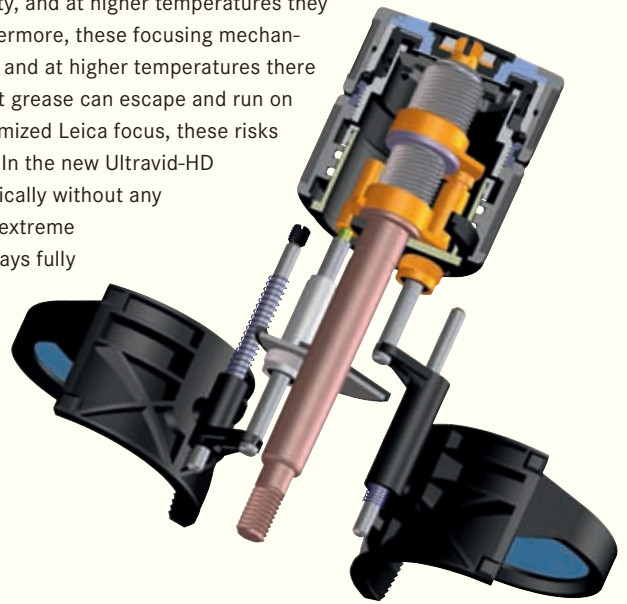

Without fluoride lenses, troublesome color fringing can occur, and so contrast and sharpness appear weakened.



Image caption of bird on the right : The new optical Leica FL lenses reduce color effects to a minimum – and so nature is rendered clearly and without distortion.

Fluoride lenses With the help of new fluoride (FL) glass, in Leica HD and APO models the color fidelity and contrast of images is further improved. Optical FL lenses are to a large part made up of calcium fluoride, a mineral with a crystalline structure. Unlike conventional optical lenses, this creates a very low level of dispersion (light scattering) and corrects aberration (imaging errors) significantly better. So as a result, the viewing experience is more natural and impressive than it has ever been before.

are always “state of the art”. Our latest innovations are proving this once more – Leica HD and APO lenses bring you impressively even closer still to nature.

Increased light transmission As a result of constant development of anti-reflex coating and reflective layer on the prisms, it has been possible to increase the previously already very high level of transmission on all HD models by at least a further 3%. Increasing the objective diameter in the new Televid models, and the use of new types of glass, are also contributing to this improvement. Especially in poor lighting conditions such as twilight, image brightness is crucial. If you then optimize the coating, especially for its suitability at night-time, with conventional lenses this is then only at the expense of color neutrality, which is a drawback for daytime viewing – the image can appear to have a blue tint. If you do it the other way round, the result can be a green tint. The new Leica HD range now reliably combines an optimum degree of image brightness with a constant level of color neutrality. In spite of this increase in optical performance, with the new Televid generation it has been possible to shorten the construction by more than 20% (compared to the APO-Televid 77 to 82, with angled sight).

Imitating nature : Leica AquaDura™ The models of binocular and spotting scopes with the new HD and APO lenses are now fitted with Leica AquaDura™, a “hydrophobic coating” which with its water and dirt-repelling properties, ensures clear visibility even in poor weather conditions. As with the leaves of the lotus plant, droplets of rain simply roll off the lens, and fingerprints and dirt particles are much easier to remove. In addition, thanks to its increased abrasion resistance, Leica AquaDura™ will protect your valuable lenses from damage even more effectively.



In a direct comparison on a Leica test glass, the advantage of Leica AquaDura™ is made particularly clear : On the coated objective on the left the rain rolls off ; in contrast, on the uncoated lens on the right, rain drops and dirt remain attached.

What is crucial to this adhesion is the angle of contact between the droplet of water and the surface. The larger the angle, the less adhesion there is on the surface (=lower adhesive strength, greater cohesiveness). With angles of contact above 90°, one speaks of a hydrophobic surface structure.



With the Leica AquaDura™ hydrophobic layer (left), a water droplet attaches itself considerably less than with a conventional hydrophilic layer (right), on which the angle is significantly less.





Leica binoculars – A century of path- breaking inventions



More detailed viewing, more discoveries – for the last hundred years, Leica has played a key role in developing the culture of long-distance viewing. Leica Product Manager Tilman Taube presents six pathbreaking chapters of this success story.



Historical advertisement from a catalog printed in 1910/1911.

On 14th May, 1907, after three years of research and testing, the first binoculars of the Ernst Leitz company in Wetzlar, a 6 x 18 Binocle, went into series production. A hundred years and countless ideas and innovations later, Leica binoculars are still providing hunters and nature watchers in particular with exciting new developments for viewing distant objects with superlative optics. Resolution, contrast, color rendering and image brightness have reached such a high standard that long-distance outdoor viewing has now become a fascinating experience rather than a necessity.

Leica sets standards in long-distance optics.

Time and again. Leica's leading position in long-distance optics is the result of many years of experience, unique competence and consistent further development. Besides innumerable continuous improvements to Leica's range of binoculars over the years, innovations of the Leitz/Leica company have made a key contribution to the general progress in long-distance optics. Until the Second World War, binoculars were primarily used for military applications. Soon after the introduction of the first Leitz prism binoculars in the year 1907, however, extra small and compact binocular models were also sold for visits to the theater and travel-

ing. Their suitability for nature watching was not specifically mentioned in catalogs at the beginning of the 20th century, but fell under the generic term "travel". Due to Dr. Ernst Leitz II's passion for hunting, the Leitz company also developed special binoculars for hunting right from the beginning. More and more of a differentiation was made between lightweight, compact models for stalking and more powerful models for raised hide hunting.

Milestones in Leica binocular history

The hundred-year road to Leica's worldwide lead in long-distance optics was paved with many small steps and outstanding milestones. The developments that culminated in the Ultravid and Geovid had modest beginnings.

An independent project right from the start :

Binocle 6 x 18 (1907 to approx. 1910) After three years of development, the first series-produced Leitz binoculars were shipped on 14th May, 1907. For the mechanical design, the engineers did not plow the conventional furrows of other binocular manufacturers, but took an independent approach based on patents from the year 1906. In those days, the casting technique was not sophisticated enough to allow the manufacture of perfect binocu-



1907

lar bodies. After extensive tests, the Wetzlar company decided to use drawn tubing or hard-rolled magnalium (alloy of magnesium and aluminum), a material with exceptionally good strength, density and weather resistance properties. Leitz patent no. 191758 was more effective for keeping dust and moisture out of the interior of the binoculars. Patent no. 192762 protected an innovative method of securing the prisms. Patent no. 2085506 used the base of the prism holder for adjustment. The adjustment screws were concealed by the leather covering and therefore protected from external intervention.

Early successes : Binodal/Militaris 6 x 21 (1908 to approx. 1919) The Binodal 6 x 21 is remarkable for its original design : The front and back caps of the prism housing are at the same time the bridges that connect the two halves. The expressive, wavy shape of the bridge on the side of the objectives makes these binoculars look strikingly different. The Binodal was also sold in an almost identical version under the name Militaris. Whereas earlier models do not feature a center rod, the revised version from 1913 onwards was produced with a center rod all the way through. The Binodal is also evidence that Leitz adopted the design for “prism binoculars with increased objective spacing” for some models after the Zeiss-Jena patent of 1893 expired in 1908. Independently of this, however, Leitz continued its models without increased objective spacing, such as the Binominia 4 x 16, which was launched in September 1908.



Top model of the early years : Marinodocce 12 x 60 (1910 to approx. 1915) In 1910, the range of binoculars was extended to include models with higher magnification (10 x, 12 x and 18 x 46, later also 42 mm), of which the 10 x and 12 x magnifications were featured in the catalog and recommended as special binoculars for alpine pursuits and traveling. The binoculars in this series have an ergonomic design and are extremely light for their size, weighing a mere 1,000 g. The double-walled eyetubes are telescopic and serve as a lens hood.

For the times, the models have considerably large fields of view (on average, subjective fields of 50° to 53°). Due to the small number produced and the short production time, they are extremely rare and therefore highly sought-after collector items. Because of their unusual shape, they are

Wetzlar. The busy Ernst Leitz Square in front of the main building of the Leitz factory in the fifties.

The first model : Leitz Binocle 6 x 18 with the original case.

1907



Top model of the early years : Leitz Marinodoce 12 x 60.

1910



1908

Successful model : Leitz Binodal 6 x 21 with the original case.



sometimes rather disrespectfully called “liver sausages”. Especially rare are models with 60 mm objective diameter like the one illustrated here, which is in a particularly good condition.

Pioneering in large-scale operations : Avidix 10 x 50 brass binoculars (1911, 1917 to 1931)

To meet the high requirements of the army and the navy, Leitz designed special binoculars for military applications : An 8 x 30 model in May 1911 was followed the same year by a 10 x 50 Porro II model with cast metal body, prism drum and drum cap and eyetube made of brass (weight 1,380 g). In his standard work “Binoculars and Telescopes”, Dr. Hans T. Seeger says of this series : “The Leitz Porro II series from the time of the First World War

is not only notable for its beautiful and practical exterior design – the binoculars are particularly comfortable to hold – but also for its optical performance and mechanical stability.” He points out that many of the binoculars that are still in the possession of collectors today never had to be cleaned from the inside or re-adjusted and can still be used. In the course of the First World War, the 10 x 50 (the first model of the series) was joined by a 12 x 60 model for the navy and, from August 1916, a 7 x 50. The delivery books of Leitz binoculars reveal that the 7 x 50 and 10 x 50 brass binoculars were manufactured in large quantities for the German military from March 1917 onwards (from serial no. 60001). Leitz was therefore the first company to concentrate on larger Porro II design binoculars and be instrumental in their breakthrough. Dr. Seeger : “Leitz brass binoculars were the first Porro II models to enter the navy, where they were used for 5 decades. After the end of World War 1, the brass binoculars were sold for a few more years as civilian models, but gradually disappeared from the scene. Production was discontinued around 1931 after the decision had been made to replace them with Porro I models.

The main Leitz factory at night.



A new start and a technology leap : Leitz

Amplivid 6 x 24 (1956 to 1962) The wide-angle Amplivid binoculars of 1956 were based on three Leitz patents of 1949 and 1953 and were an absolutely new development that was to pave the way for the tremendous success of pentaprism binoculars. Alfred Hengst (long-standing senior binocular designer of Leica) : “These binoculars stood out



1917

This design became a classic :
Leitz Aviodix 10x50.

A new start and a technology leap :
Leitz Amplivid 6x24.



1956



1958

Way ahead of their time :
Leitz Trinovid 7x42.

from earlier models due to their gigantic field of view of 212 m at a distance of 1000 m and their extremely elegant and compact design. For the first time in the history of hand-held telescopes, the designers used an inverting system consisting of a surface mirror (...) and a pentaprism.” Extreme wide-angle binoculars have become very rare and there are hardly any to be had on the market at the moment. Besides its significance as a “binocular milestone”, this is another reason why the Amplivid is still so popular.

Way ahead of its time : The first Leitz Trinovid series 7x42 and 8x40 (1958) In the further course of the development strategy that started with the Amplivid, a small series of 7x42 and 8x40 binoculars was produced in 1958. These models had a subjective field of view of 70° and 80° respectively (binoculars are regarded as wide-angle models from a field of view of 60° onwards). Unlike the Amplivid, they featured true internal focusing. These models were therefore the first to combine the two special features of modern high-quality binoculars – slender pentaprism design and internal focusing. For the first time, these binoculars were given the name Trinovid, for “Tri” (three) “Nov”el innovations : the compact, ergonomical design, the true internal focusing and the superlative optical performance. However, it was so expensive to produce these models that they cost 650 DM to buy – unaffordable for many customers at that time. Therefore, production of these first Trinovids was soon discontinued, which makes them coveted collector items today.

A far-sighted history. To be continued.

The binoculars mentioned here are just a few of the most important milestones on the road to the Ultravid and Geovid binoculars of today. They show the resolve and skill that have taken Leica to the top of the binocular market. Now as ever, Leica binoculars are the number one choice, particularly when there are important observations to be made – as in 1968 on board the Apollo space missions or this year in bird counts in Costa Rica. And the story of Leica binoculars does not end here. Read on to find out how Leica’s latest developments in long-distance optics have the optical, mechanical and electronic excellence to make nature watching even more exciting for you, too.



Experience Nature Nature constantly challenges those wishing to brave it. These free spirits are out to enjoy the freedom of the outdoors and to find that unforgettable moment, which only nature can provide. Nature is their passion. They know best of all how difficult it can be to identify that rarest of birds under the most trying conditions. Our quest is to bring enthusiasts closer to nature, and coupled with our Leica expertise, make our optical instruments the ideal field companions. Even under the most grueling conditions, such as extreme temperature changes and constant physical abuse, our products exceed expectations. The reason for this being that Leica binoculars, spotting scopes, and laser rangefinders are the result of many years of experience, uncompromising quality standards and a continuing dedication to excellence. Leica's product development is driven by international "Innovation Teams" comprised of experts and users. This has also resulted in a wide range of patents, e.g. for the unique combination button for the central focusing device, and the way in which the laser rangefinder works.

Observe and preserve We see it as our duty to protect the environment. Therefore, Leica only uses environmentally friendly materials and technology. As such, all glass is lead- and arsenic-free, and has been so for years. Leica is also active worldwide in protecting endangered species and conserving crucial habitat.

Leica Sport Optics supports the following projects and organizations :

American Birding Association (ABA), USA

www.americanbirding.org

The ABA represents a whole range of birding interests, from identification and education to listing and conservation. ABA actively promotes the economic and environmental values of birding, and we encourage the conservation of birds and their habitats.

New Jersey Audubon Society (NJAS), USA

www.audubon.org

The mission of the National Audubon Society is to conserve and restore natural ecosystems, focusing on birds and other wildlife for the benefit of humanity and the earth's biological diversity.

Naturschutzbund Deutschland (NABU) e.V., Germany

www.nabu.de

Among other things the NABU exerts itself for the conversation, creation and improvement of the life bases of the flora and fauna. Besides, the protection of birds finds special consideration.

The Katinger Watt NABU Nature Centre, Germany

www.nabu-katinger-watt.de

The NABU Nature Centre at Katinger Watt organizes guided tours and exhibitions and it also protects an 1,100 hectares (7,413 acres) nature preserve that serves as a resting area for migratory birds, making it a paradise for bird fanciers.

Crane Information Centre Gross Mohrdorf, Germany

www.kraniche.de

The Baltic coast, between the islands of Rügen, Bock and the Zinger Peninsula contains the largest crane resting places of Central Europe. The Information Centre takes care of the protection of the cranes and it looks after the numerous nature friends who come here to watch these majestic birds, especially during their spectacular autumn migration.

National Park Schleswig-Holstein's Wadden Sea, Germany

www.wattenmeer-nationalpark.de

The national park's objective is to protect the wadden sea ecosystem's diversity by ensuring its undisturbed development.

British Butterfly Conservation, UK

www.butterfly-conservation.org

The British Butterfly Conservation Organization has prepared conservation programs for more than 60 threatened species of butterfly and moth.

Birdlife International, UK

www.birdlife.org

Birdlife International is involved in the protection of sea birds (actually mainly albatrosses and petrels).

Oriental Bird Club (OBC), UK

www.orientalbirdclub.org

OBC research projects for bird conservation in Asia.

NABU waterfowl reserve in Wallnau, Germany

www.nabu-wallnau.de

The waterfowl reserve in Wallnau has set itself the goal of protecting and maintaining this unique landscape on the west coast of Fehmarn, which is characterized by ponds, bulrushes, meadows and small areas of woodland, which is managed in the interests of animals and plants to make it even more attractive. It is a true experience for all friends of nature, young or old.

NABU-Naturschutzstation e.V. in Kranenburg, Germany

www.nabu-naturschutzstation.de

NABU nature conservation campaigns on behalf of people and nature, and in the region of "de Gelderse Poort" in the area surrounded by the cities of Kleve, Nijmegen, Arnhem and Emmerich, carries out numerous nature conservation activities. One spectacle is the huge flocks of wild geese from the Arctic which winter here.





The Duovid class : Two binoculars in one

The LEICA DUOVID 8 + 12 x 42 and 10 + 15 x 50 are the only premium performance binoculars with two magnifications. No matter what the situation, whether it is over long distances or during critical low-light conditions, the Leica Duovid adapts to it perfectly. The lower magnification (8 x with the 42 Duovid or 10 x with the 50) allows for shake-free viewing and a large field of view. By switching to the higher magnification (12 x or 15 x respectively) one achieves greater detail recognition. In contrast to monocular add-on power boosters, a binocular booster is already integrated in the Duovid – lightweight, easy to operate and with a large field of view. Both models are well-balanced and feature an outstanding ergonomic design, thereby allowing for virtually shake-free viewing, even at high magnification. Other technical innovations, such as the Leica HighLux-System HLS™ and the Automatic Diopter Compensation ADC™ when switching between powers, make the Duovid a unique and versatile instrument.

LEICA DUOVID 10 + 15 x 50





LEICA DUOVID 8+12x42

LEICA DUOVID 10 + 15 x 50 – the binocular spotting scopes

With its 15 x magnification, the Duovid with 50 mm objective lens bridges the gap between binocular and spotting scope.

LEICA DUOVID 10 + 15 x 50

This Duovid is a high performance binocular that, with a flick of the wrist, becomes a binocular spotting scope. The 10 x magnification allows for shake-free viewing and a larger field of view. By switching to 15 x one achieves a level of detail recognition previously found only in spotting scopes. Due to its high level of optical performance, the 50 mm Duovid is also well suited for astronomy – it comes delivered with a tripod adapter to provide added stability.

The ergonomic design and the soft-touch rubber armoring (available in black or green) allow for a secure and shake-free handling of the binocular, even while wearing gloves.



The 15 x magnification is ideally suited for viewing over long distances. The 10 x magnification, on the other hand, gives you a good overview.

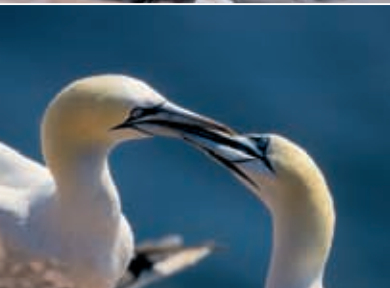

“Without a doubt, the option to choose between two magnifications is an advantage in many applications. Truly remarkable though is the fact that the Leica engineers managed to realize binoculars with such a feature without any sacrifices whatsoever in terms of image quality.” (Hartmut Syskowski, specialised editor “Pirsch”)

LEICA DUOVID 8 + 12 x 42 – the most flexible 42 mm binoculars

Unique 12 x magnification in a 42 mm glass, which allows for great detail recognition.



— LEICA DUOVID 8 + 12 x 42

The compact 42 Duovid offers 8 x magnification for a large field of view, as well as 12 x magnification for greater detail recognition. As with the 50 mm model, this Duovid features the sliding eyecups with two click stops, which ensure the ideal eye relief for every user.

— To switch between magnifications, one must adjust the ring on each tube accordingly. Due to the Automatic Diopter Compensation ADC™ your previously set diopter will automatically adjust itself to the new magnification.

“I use the Duovids for the extra flexibility they provide. I might want to watch dragon flies at one moment, and then a distant sea-eagle ; the rapid change of magnification makes that easy. I try to encourage my students too to scan a scene with 8 x magnification, and then switch to 12 x for the close view.” (Dr. Dreyer, Germany, Head of the Zoological Museum of Kiel University, specialist author)

Due to its extreme twilight performance, the Duovid achieves great detail recognition at 12 x and 15 x magnification, even under poor light conditions. However, with continued deteriorating light conditions, one should switch to 8 x or 10 x magnification, since the binoculars render brighter images at lower power settings.



The Duovid class : Two binoculars in one

Key features at a glance

— Two magnifications

The flexible binocular class with both – high magnification and a large field of view – in one product. High magnification for long distances and minute details. Low magnification for image stabilization and a large field of view.

— Extreme brilliance

Extremely high resolution and a color-fringe-free image due to the Leica HighLux-System HLS™, an innovative multi-layer lens coating with Leica HDC™ and a four-lens objective with an achromat.

— Easy to use

Automatic Diopter Compensation ADC™ : when switching between magnifications the diopter automatically adjusts. Multifunction Center-drive : comfortable, smooth focusing and easy diopter setting.

— Robust

Strong aluminum die-cast housing and soft-touch rubber armoring protect the binocular from damage, while at the same time ensuring secure handling of the product, even when wearing gloves. Functions perfectly under all environmental conditions from -25°C to +55°C (-13°F to +131°F), waterproof to 5 m (16,4 ft), nitrogen-filled.



LEICA DUOVID 10 + 15 x 50 – the binocular-spotting scopes.

In black rubber armoring : **Order No. 40 420**



LEICA DUOVID 8 + 12 x 42 – the most flexible 42 mm binoculars.

In black rubber armoring : **Order No. 40 400**



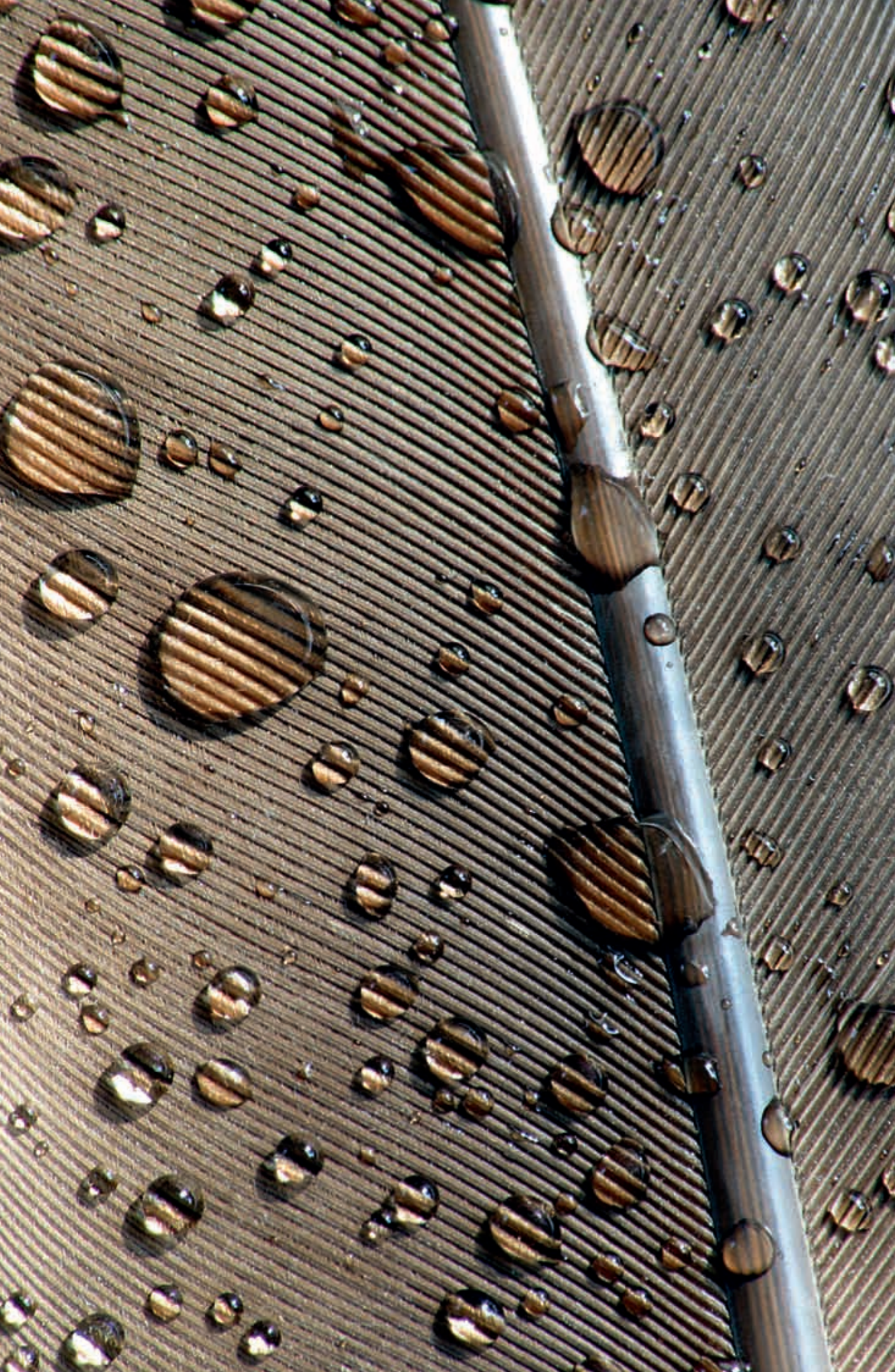

The Ultravid class : “Ultravid” redefined Previously, the Leica Ultravid class had already impressed with its outstanding technical achievements and its superior optical quality. Now, with the innovative Ultravid HD models with 50, 42 and 32 mm objective diameters, the Leica engineers have once again succeeded in setting new standards. The use of new, fluoride lenses (FL) further optimizes the color fidelity of the images. It has been possible to further increase the level of image brightness – without compromising color fidelity and contrast which are often necessary. In terms of stray light reduction too, the refined HD models achieve new top-of-the-range performance, and thus once again underline the pioneering role played by Leica. As a further benefit, the Ultravid HD range has Leica AquaDura™, a new kind of coating for exterior glass surfaces which improves viewing comfort. Fingerprints and dirt can be removed more easily than ever. Moisture simply rolls off the surface and visibility remains unimpaired. This has been made possible by a special glass surface structure. In a similar way to the lotus plant, dirt and moisture find it more difficult to take hold. However, Leica AquaDura™ does not have any negative influence on the transmission performance of the optical system, and also provides better protection against scratching. It was also possible to further optimize the focusing mechanism. So the functioning properties remain smooth – whatever the surrounding temperature. The end result makes the latest Ultravid HD generation the first choice for all nature observers who do not want to accept compromises in their binoculars, and who expect the highest level of performance. So experiencing nature is even more fascinating.

LEICA ULTRAVID 8x20 BL





LEICA ULTRAVID 12x50 HD

LEICA ULTRAVID HD 50 – greater sight in low light The Ultravid 50 series are ideal for viewing right into the depths of dusk due to optimized image performance, thanks to new high-definition lenses and Leica AquaDura™ coating for greater visibility in poor weather conditions.

— **LEICA ULTRAVID 8 x 50 HD**

Fatigue-free viewing, even under poor light conditions. The 8 x magnification guarantees a steady, sharp image, without the need to constantly refocus.



— **LEICA ULTRAVID 10 x 50 HD**

These binoculars offer impressive high performance in poor lighting conditions. Detailed viewing is possible even into darkness. The new HD optics ensures that little bit extra in terms of light yield.



— **LEICA ULTRAVID 12 x 50 HD**

The 12 x magnification allows for great detail recognition over long distances. The new FL lenses increase the color fidelity and reduce color fringing on high-contrast transitions in images. Moreover, these high-performance binoculars offer an impressive close focus distance of 3.2 meters.

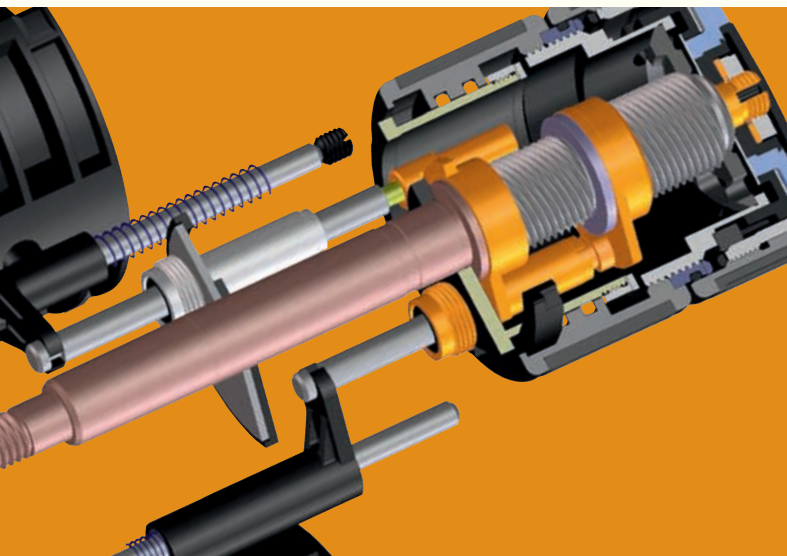

Even extreme cold cannot keep the robust Ultravids from delivering the ultimate viewing experience : the new focusing mechanism on the Leica Ultravid HD models works with high-performance Teflon disks and almost no lubrication. This ensures constant smooth focusing – even at temperatures as low as -25°, where other binoculars would surely fail.

LEICA ULTRAVID HD 42 – the robust all-round favourite They are almost as compact as 32 mm models and nearly as high-aperture as 50 mm binoculars. But the 42 mm Ultravids also impress due to the benefits of the new HD models – Leica AquaDura™ and new FL lenses.



— **LEICA ULTRAVID 7 x 42 HD**

A large field of view with great edge-to-edge sharpness, combined with a bright and steady image, characterize this binocular.



— **LEICA ULTRAVID 8 x 42 HD**

The multi-talented binocular that delivers images rich in contrast both during the day and at twilight. The ratio of brightness and weight, of magnification and field of view, make this model perfect for any application.

— **LEICA ULTRAVID 10 x 42 HD**

The most powerful binocular in the 42 mm Ultravid class. The redesigned eyecups allow for a very comfortable positioning of the eye. This becomes very apparent with the improved image steadiness while viewing over great distances.

New ergonomics for relaxed handling : the formed thumb supports on the rear of the 50 mm and 42 mm HD models ensure that the binoculars fit in your hands without slipping. The large central focusing device enables relaxed, natural handling.



LEICA ULTRAVID BL 42 – lightweight in a classic design The leather covered 42 mm BL models are particularly elegant, are reminiscent of the classic binoculars and cameras that made Leica famous. Due to the leather covering, they weigh less than 700 g (24.7 oz).

— **LEICA ULTRAVID 8 x 42 BL**

A field of view of 130 m at an 8 x magnification. An image that is rich in contrast both during the day and at twilight.



— **LEICA ULTRAVID 10 x 42 BL**

The most powerful binocular in the 42 mm Ultravid class. The redesigned eyecups allow for a very comfortable positioning of the eye. This becomes very apparent with the improved image steadiness while viewing over great distances. This high-power binocular is, just as the 10x42 BL model, equipped with new eyepieces designed to comfortably accommodate eyeglass wearers.



Magnesium and titanium are the strengths of the lightweight 50 mm, 42 mm and 32 mm Ultravids. A housing made entirely from magnesium and the hinge axle from high-strength titanium are a guarantee for durability and enable the Ultravid models to be so extraordinarily light. The newly designed central focusing device is an exceptional functional achievement. The focusing mechanism has been further improved thanks to a constant smooth action which is free of any play. Due to the extremely short focusing movement of slightly more than one rotation, the ideal point of focus can now be quickly found at all times. The diopter reading can comfortably be seen on the scale and the large focusing wheel is easy to operate.

LEICA ULTRAVID HD 32 – the “handy” binocular The new 32 mm HD models stand out not because of their extreme compactness, but also their new HD lenses, which gives them increased high-performance.



— LEICA ULTRAVID 8 x 32 HD

High-performance binocular with 32 mm objective lens diameter, 8 x magnification and a large field of view of 135 m allows for a great overview and steadiness of image. This binocular is the new reference class for those seeking minimal weight yet maximum optical performance.

— LEICA ULTRAVID 10 x 32 HD

The most powerful 32 mm model not only impresses over great distances, but also has an astonishing close focus of 2.1 m.

In terms of optical performance and handling, you might believe that you are holding a 42 mm binocular, when in fact it is a 32 mm binocular.



LEICA ULTRAVID BR 25 – the stars among the compacts The 25 mm models combine ruggedness and brightness in a pocket-size dimension : The rubber armoring protects the binocular during tough outings, the HighLux-System HLS™ allows for fascinating images.



LEICA ULTRAVID 10 x 25 BR

Due to its high magnification, the lightweight, black rubber armored compact binocular displays distant objects with extreme sharpness and contrast.



“If you keep a pair of these little gems in your pocket you will never miss that unforgettable moment !” (Dick Forsman, Finland, ornithologist, author of many specialist books and international expert on birds of prey)



“...The best compact binocular in the test. From all magnification groups one of the few binoculars with 'very good' optical characteristics.” (Stiftung Warentest)

LEICA ULTRAVID BL 25 – brilliant elegance These lightweight binoculars with a classic leather covering are the ideal companions for all those expecting a high level of optical performance, whether it is in nature or the city.



— **LEICA ULTRAVID 10 x 25 BL**

The extremely minimal weight of 255 g (9 oz) and the elegant design allow one to always carry it along, even when at the opera or the open-air event.

Almost all Ultravid elements could be miniaturized to fit into this smallest model of the Ultravid class. Due to this fact, even these “minis” achieve the highest standards set forth by this reference class. Brighter, sharper, more compact and robust than any previous binoculars with these objective lens diameters.



LEICA ULTRAVID BR 20 – robust High-Tech-Minis The small Ultravid BR models are not only ultra-rugged and ultra-bright, but they are small premium-performance binoculars that one can always carry around.



— **LEICA ULTRAVID 8 x 20 BR**

Impact protected, water-proof binocular with a field of view of 110 m and a close focus of 2.2 m. Shake-free viewing due to the 8 x magnification. The Leica HighLux-System HLST™ ensures a bright image. It only weighs 240 g (8.5 oz).



Big optic in its smallest size. Not only are the 25 mm and 20 mm Ultravids ultra-rugged, but due to aspherical lenses, they are also ultra-bright. They achieve a large, color-fringe-free image with edge-to-edge sharpness previously unheard of in the compact class.

LEICA ULTRAVID BL 20 – the nice little ones With their black leather covering, the smallest Leica “power packages” are both elegant and powerful.



— LEICA ULTRAVID 8 x 20 BL

They can easily be folded to save room when visiting the opera or a concert and only fall into light by their brilliant image.

The newly developed diopter compensation with its “single-button-operation” and large focusing wheel make the smallest Ultravids easy to handle. Naturally, these smallest of binoculars are ideally suited for eyeglass wearers.



The Ultravid class : “Ultravid” redefined

Key features at a glance

— Ultra-lightweight

Magnesium die-cast housing and a titanium center-hinge for lightweight stability and strength. Aspherical lenses allow for the lightweight in the 20 mm and 25 mm models.

— Ultra-bright

Extremely high resolution and a color-fringe-free image due to the Leica HighLux-System HLS™, an innovative multi-layer lens coating with Leica HDC™ and a four-lens objective with an achromat (aspherical lens technology in the 8 x 20 and 10 x 25 models). Furthermore, all HD models have fluoride lenses for maximum color neutrality.

— Ultra-rugged

The Ultravid HD binoculars have been given a hydrophobic coating, which repels water and grease. Droplets of rain on the lens simply roll off, and fingerprints can also be more easily removed. Soft-touch rubber armoring protect the binoculars from damage, while at the same time ensuring secure handling of the product, even when wearing gloves. Functions perfectly under all environmental conditions from -25°C to +55°C (-13°F to +131°F), waterproof to 5 m (16,4 ft), nitrogen-filled, impact resistant.

— Ultra-ergonomic

Functional design with integrated thumb rests (50 mm and 42 mm HD models), natural placement of focusing mechanism and perfectly balanced for long, relaxed viewing. Multifunction center drive : comfortable, easy focusing and diopter setting.



LEICA ULTRAVID HD 50 – greater sight in low light.

In black rubber armoring :

8 x 50 HD **Order No. 40 295** / 10 x 50 HD **Order No. 40 296** / 12 x 50 HD **Order No. 40 297**



The Ultravid HD models are expected to be available for delivery from October 2007.

LEICA ULTRAVID HD 42 – the robust all-round favourite.

In black rubber armoring :

7 x 42 HD **Order No. 40 292** / 8 x 42 HD **Order No. 40 293** / 10 x 42 HD **Order No. 40 294**



The Ultravid HD models are expected to be available for delivery from October 2007.

LEICA ULTRAVID BL 42 – lightweight in a classic design.

In elegant black leather covering :

8 x 42 BL **Order No. 40 271** / 10 x 42 BL **Order No. 40 272**





LEICA ULTRAVID HD 32 – the “handy” binocular.

In black rubber armoring :

8x32 HD **Order No. 40 290** / 10x32 HD **Order No. 40 291**

The Ultravid HD models are expected to be available for delivery from October 2007.



LEICA ULTRAVID BR 25 – the stars among the compacts.

In black rubber armoring :

10x25 BR **Order No. 40 253**



LEICA ULTRAVID BL 25 – brilliant elegance.

In elegant black leather covering :

10x25 BL **Order No. 40 257**



LEICA ULTRAVID BR 20 – robust High-Tech-Minis.

In black rubber armoring :

8x20 BR **Order No. 40 252**



LEICA ULTRAVID BL 20 – the nice little ones.

In elegant black leather covering :

8x20 BL **Order No. 40 256**





The Trinovid class : Proven technology for the ambitious viewer For many years, the compact Trinovid binoculars have been proving themselves as trustworthy companions all around the world. If you are wanting to move into high-quality viewing with excellent optics, but you want to limit your equipment to a minimum, the small lightweights with 20 mm or 25 mm objective diameters are almost unbeatable. Thanks to HDC™ multi-layer coating, they display neutral-colored, richly contrasting images which are full of brilliance and sharpness. Whether out in the wilds, at cultural events, on trips, at sports meetings or in the theatre – with a Trinovid BCA you are much closer to the action. The robust housing made from die-cast aluminum and the easy operation make viewing in every situation a pleasure. Folded up, the compact binoculars fit effortlessly into any purse and at outdoor activities you will hardly notice the weight. All these benefits have been recognized by the Stiftung Warentest consumer magazine : They gave both Trinovids the rating of “very good”.



LEICA TRINOVID 8 x 20 BCA



LEICA TRINOVID 10 x 25 BCA

LEICA TRINOVID BCA 25 – superbly compact The format of compact binoculars is immediately recognizable. For example, you can take it anywhere with you, it gives you excellent service, and it was given the rating of “very good” by the Stiftung Warentest consumer magazine.

— **LEICA TRINOVID 10 x 25 BCA**

A compact binocular weighing only 255 g (9 oz) that renders sharp, contrasty images. Great detail recognition over long distances, thanks to its high magnification.



“... best 10 x 25 of its class with greatest ease of handling.” (Stiftung Warentest)



LEICA TRINOVID BCA 20 – powerful little ones As the smallest of all Leica binoculars, the handy 20 mm Trinovids show their true value when out and about – and they are highly praised by their users.



— LEICA TRINOVID 8 x 20 BCA

A versatile binocular with a field of view of 110 m and a close focus of 3 m. A steady image due to the 8 x magnification. When folded, it is just 9 x 6 cm small.

“One of the very best in test, especially durable ...” (Stiftung Warentest)

“Impossible to improve – the Leica dominates the competitors in almost all categories ...” (Outdoor-Magazin.com winner : Trinovid 8 x 20 BCA)



The Trinovid class : Proven technology for the ambitious viewer

Key features at a glance

— Proven

Legendary binoculars with excellent optical and mechanical performance.

— Bright

Innovative multi-layer lens coating with Leica HDC™. A three-lens objective with an achromat guarantees an image rich in contrast with great color rendition.

— Easy to use

The BCA models have a centre drive for focusing. The dioptre setting is easily done on the right objective.

— Robust

Stable aluminum die-cast housing and soft-touch armoring protect all optical components from damage and provide a firm grip. Functions perfectly under all environmental conditions from -25°C to +55°C (-13°F to +131°F), impact resistant.



LEICA TRINOVID BCA 25 – superbly compact .

In black rubber armoring :

10x25 BCA **Order No. 40 343**



LEICA TRINOVID BCA 20 – powerful little ones.

In black rubber armoring :

8x20 BCA **Order No. 40 342**





The new Televid class : Experience nature close up

Experience the spectacle of nature close up, without disturbing it – for over ten years this has been the domain of the Televid high-performance spotting scopes with their optical performance and this special viewing quality which has set the standard. The latest Leica Televid generation redefines this standard : talking to experienced users, asking detailed questions about tried and tested constructions and completely new developments have led to two sophisticated and elegant lines with 82 mm and 65 mm diameter objectives. They are the most compact spotting scopes with the shortest close focus distance in their class. The innovative High Definition models (HD) and especially the APO versions with their highly elaborate, apochromatic objectives use new kinds of fluoride glass (FL) for an image quality that gets even closer to the ideal. The fully rubber-protected magnesium die-cast housing keeps the sophisticated optics safely protected from tough conditions outdoors and always remains silent. The newly developed Leica AquaDura™ coating reduces fogging and allows moisture droplets and dirt to simply roll off ensuring clear visibility – even in wind and rain. Another innovation is the completely newly developed variable wide-angle eyepiece with 25 x to 50 x magnification. It provides the discerning observer with a spectacular subjective field of vision of over 60° which remains sharp right up to the edges – across the entire zoom range ! This is unique, and ensures a totally new viewing experience with fantastic magnification. With these and many more benefits, the innovative Televids help you to experience and understand nature even more intensively.

LEICA TELEVID 65 HD





LEICA APO-TELEVID 82

LEICA TELEVID HD 82 – high-aperture and rich in detail Whether as a straight or angled spotting scope, with its larger objective diameter and new FL lenses, the LEICA TELEVID 82 HD offers greater optical performance for insights into nature that are rich in detail – from dawn till dusk.



— LEICA TELEVID 82 HD

High-definition spotting scope for color-fringe-free, high-contrast images thanks to FL lenses, stray light optimization and Leica AquaDura™ coating. Superbly short close focus distance of only 3.9 meters. Rubber-protected magnesium housing, waterproofed up to 5 meters. In a set together with the variable eyepiece 20 – 60x.



Leica and Manfrotto® – a carefully-considered association. Manfrotto tripods are amongst the world's most frequently used tripods for high-quality nature and bird watching. The foot of the new Televid spotting scopes now click straight into the quick-change system of Manfrotto tripod heads – either horizontally or vertically. Which makes a quick-change plate superfluous. In addition, the familiar 1/4" connecting thread with rotation prevention for other quick-change plates is also available.

LEICA APO-TELEVID 82 – Top-of-the-range imaging Compared to the previous models, apochromatically corrected optics combined with the new FL lenses and an 82 mm diameter objective increase the light yield by more than 6%, and the imaging performance is clearly visible when viewing the finest, natural details and structures in the highest possible resolution. For that little bit extra in terms of experiencing nature, especially in poor lighting conditions.



— LEICA APO-TELEVID 82

Top-of-the-range spotting scope delivering professional standards for all users. An innovative 4-part fluoride lens objective for maximum color fidelity and richness of contrast. Optically neutral front lens glass to protect the APO optic, and Leica AquaDura™ coating. Particularly short close focus distance of 3.9 meters. Rubber-protected magnesium housing, waterproofed up to 5 meters. Comes with the new variable wide-angle eyepiece 25 – 50x WW ASPH.

Leica AquaDura™ ensures greater visibility in wind and rain. It is a cold morning and the lens fogs up – that is not much fun. Fingerprints, dust and rain are also annoying when viewing. The innovative Leica AquaDura™ coating considerably reduces these disturbing factors. As with the lotus plant, this new water and dirt-resistant protective layer on the outer glass surfaces ensures that dirt and moisture are barely able to take hold on the specially adapted surface structure of the optic. The benefit for you : reduced cleaning required – which leaves more time for viewing.

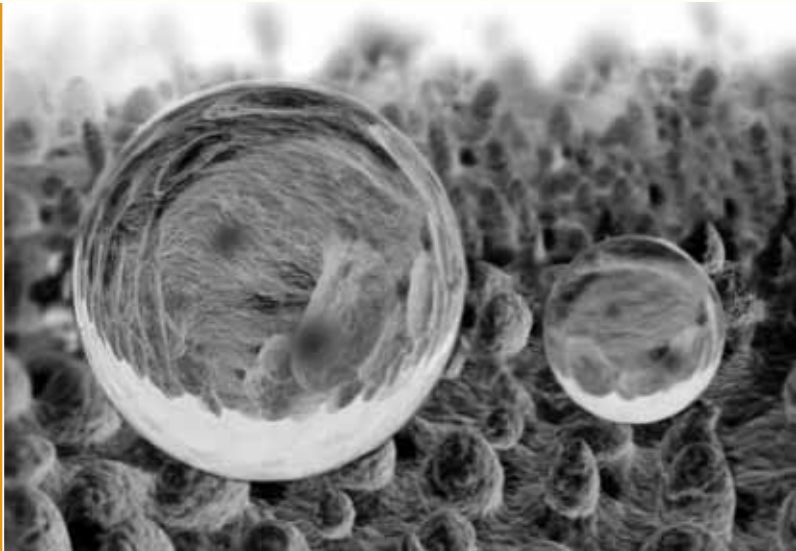

LEICA TELEVID HD 65 – compact high performer High-definition optics characterizes even the smallest of the “big” ones : new fluoride lenses in combination with a particularly small housing made from robust magnesium make the 65 mm model ideal for anyone wanting to be out and about especially during the day with excellent optics but not much equipment.



— **LEICA TELEVID 65 HD**

Small, light straight or angled spotting scope with HD optic and Leica AquaDura™ coating. Excellent resolution, natural bright color reproduction. The shortest close focus distance in its class (only 3.2 meters). Rubber-protected magnesium housing, waterproofed up to 5 meters, complete with variable eyepiece 20 – 60 x.



Elaborate range of accessories enhance your viewing pleasure : Cordura accessories bag with innovative, almost silent magnetic catch system and carrying strap, so that you can also carry your equipment incl. tripod on your shoulder. Newly developed LEICA DIGITAL ADAPTER 3 for particularly flexible and high-quality digiscoping (digital photography through a spotting scope) with the “small digitals” from the C-Lux or D-Lux range, and many other digital compact cameras and camera phones. The range of accessories is rounded off with the 32 x WW wide-angle eyepiece with extreme image definition and an extra-large field of view, as well as the new photo adapter for attaching SLR cameras to the spotting scope.

LEICA APO-TELEVID 65 – uncompromising optic in small-format

For nature and bird watchers who are particularly active during the day, and prefer the smaller size and weight, but do not want to make sacrifices when it comes to optic performance. For deep, clear insights into nature.



— LEICA APO-TELEVID 65

Top-class small, compact spotting scope, only 30 cm in length. With 4-part fluoride objective lens system for the best possible color accuracy, image definition and detail. The shortest close focus distance in its class (only 3.0 meters). As a straight or angled spotting scope, with rubber-protected magnesium housing, waterproofed up to 5 meters, complete with new variable wide-angle eyepiece 25 – 50 x WW ASPH.

The new generation of Televids is aimed at those who have high demands and will accompany you through thick and thin. The scope's body and eyepiece are nitrogen-filled – independently of each other – waterproofed up to 5 meters. The automatic eyepiece lock on the new bayonet system ensures that all eyepieces are held firmly in place. The Leica dual-focus system is reinforced by an additional crosspiece. The full rubber protection of the robust magnesium housing which fits comfortably in your hand, absorbs shocks effectively and guarantees silent viewing. On the APO models, an optically neutral front lens glass additionally protects the sensitive optic from harsh weather conditions.



The new Televid class : Experience nature close up

Key features at a glance

— New top-class optics

High-end spotting scopes with improved image performance thanks to an entirely new optical construction and new FL lenses on all HD and APO models. Optimized stray light factor ensures high-contrast and detailed images which remain sharp right up to the edges, even with strong backlight. Enlarged objective diameter increases the light yield by more than 6 % compared to the previous models. Leica AquaDura™ coating optimizes visibility especially in poor weather conditions.

— Flexible usage

Thanks to the shortest close focus distance in its class (only 3.2 meters/3 meters for the 65 mm and 3.9 meters for the 82 mm models), it is not only objects far away that can be viewed close up and in great detail, but it is also ideal for insect watching.

— Particularly compact and robust

The most compact high-performance spotting scopes in their class in a robust, fully rubber-protected magnesium housing. Optically neutral front lens protection glass on all APO models, automatic eyepiece lock integrated into the new bayonet system, functions perfectly in all weather conditions between -25°C and +55°C (-13°F to +131°F), spotting scope and eyepiece independently nitrogen-filled and waterproofed up to 5 m (16,4 ft).

— Best accessories

Innovative Cordura accessory bag for silent observation and greater carrying comfort, newly developed digital adapter 3 for particularly flexible, high-quality digiscoping, unique variable wide-angle eyepiece and 32 x wide-angle eyepiece which remains sharp right up to the edges, photo adapter for attaching SLR cameras.

LEICA TELEVID 82 HD – high-aperture and rich in detail.

Straight view **Order No. 40 118** / Angled view **Order No. 40 120**



The Televid HD models are expected to be available for delivery from July 2008.

LEICA APO-TELEVID 82 – first-class imaging.

Straight view **Order No. 40 119** / Angled view **Order No. 40 121**



The Televid APO models are expected to be available for delivery from April 2008.

The new Televid eyepieces The Leica brand's reputation rests on the development and manufacture of the world's finest optics for uncompromisingly quality images. The three Leica Televid eyepieces are impressively proving this once more. For the first time, a unique variable wide-angle eyepiece is complimenting the eyepiece range. Its performance data speaks for itself : 25 – 50 x WW ASPH. with a subjective field of view of more than 60° across the entire zoom range. Consequently, Leica enables viewing experiences which are unique on this scale. The newly developed interchangeable bayonet system has an integrated, automatic eyepiece lock, which fixes all eyepieces securely to the scope. Thanks to the entirely new construction of the optical system, the eyepiece's focal length is now also independent of the 65 mm or 82 mm scope being used, and is retained when the eyepieces are changed. All eyepieces have new, rubberized function elements and comfortable rotating eyecups, which significantly increases comfort when viewing. As a result, the eyepieces are particularly good to get hold of and also easy to handle when wearing gloves. All eyepieces are nitrogen-filled and so they are also waterproofed up to 5 meters, whichever the spotting scope.

The 20 – 60 x variable eyepiece comes supplied with the HD scopes, and the new variable wide-angle eyepiece 25 – 50 x WW ASPH. Is supplied with all APO models. The fixed focal length wide-angle eyepiece 32 x WW, with its excellent focusing performance and a particularly large field of view is a worthwhile addition to the range of equipment. All eyepieces are also available individually as accessories.



32 x WW
Order No. 41 016



20 – 60 x (Zoom)
Order No. 41 018



25 – 50 x WW ASPH.
Order No. 41 019

LEICA TELEVID 65 HD – compact high performer.

Straight view Order No. 40 126 / Angled view Order No. 40 128



The Televid HD models are expected to be available for delivery from July 2008.

LEICA APO-TELEVID 65 – uncompromising optic in small-format.

Straight view Order No. 40 127 / Angled view Order No. 40 129



The Televid APO models are expected to be available for delivery from April 2008.

Leica Digiscoping To do so, simply combine a Leica Televid spotting scope with a compact digital camera and you will have a photographic outfit with a super telephoto lens. Digiscoping will greatly expand your ability to observe the brilliance of nature.

Digiscoping is a fantastic way of photographing nature from close up. For this, Leica offers you everything you need, optically perfectly coordinated. The high-performance **65 mm or 82 mm Televid spotting scopes**, and in particular the **LEICA APO-TELEVID 82** are suitable for perfectly color-fringe-free, detailed digiscoping pictures. With the new **LEICA DIGITAL ADAPTER 3** you can very easily and quickly combine a spotting scope with a digital camera to create a photographic outfit with a super telephoto lens with focal lengths of more than 2,000 mm.



The **Leica C-Lux and Leica D-Lux** cameras, with their optical image stabilizer Mega O.I.S., enable you to take pictures almost shake-free, even with extreme focal lengths and in low light. Check your images on the large display and, if necessary, finally rework them on your computer using the Adobe Photoshop Elements software supplied. Whether you then archive your pictures, print them out to put in an album, print them on high-quality photo paper, include them on your website, or send them to specialist magazines – digiscoping will meet all your needs. The photos shown here demonstrate the image quality that you can achieve with Leica digiscoping.

As a compact digital camera with the strengths of an SLR camera, the **LEICA V-LUX 1** “superzoom” is the ideal addition for the nature photographer. With its 12x optical zoom and optical image stabilizer, there is hardly any photographic situation which you are not up to with your V-Lux 1 – especially when it needs to be quick. Its focal length is equal to that of a 10x pair of binoculars. Thanks to a 180° horizontally and vertically flip-out 2" display, it is suitable for spontaneous nature photographs in which unusual angles are important – from a worm’s-eye view to a bird’s-eye view.



“For me, a camera like the V-Lux is about opportunity. It enables me to photograph wildlife in a wide range of circumstances that might arise when I am on a trip. It is not about serious, full-on, stake out wildlife photography. The V-Lux superbly complements my digiscoping.”
Steve Dudley, birder and naturalist, England





The Geovid class : Perfect observation and range-finding The LEICA GEOVID BRF binoculars are truly professional orientation tools. They are the first high-performance binoculars to feature an integrated laser rangefinder with a range of up to 1,200 meters/ 1,300 yds. A Geovid always tells you exactly how far away you are from your target. Despite the rangefinder, the Geovids are no larger than traditional binoculars. With their robust design and non-slip rubber armoring they are also well prepared for the toughest orientation challenges in open country. The new, extra bright Geovid 15 x 56 BRF enables observation over great distances in unprecedented detail.



LEICA GEOVID 8 x 42 BRF

LEICA GEOVID 15 x 56 BRF



LEICA GEOVID 56 BRF – observing and rangefinding in poor light conditions Leica was the first optics specialist who succeeded in combining uncompromised high-performance optics with a laser rangefinder in an especially compact binocular with a front lens diameter of 56 mm.

— **LEICA GEOVID 8x56 BRF**

High-performance binocular with a 7 mm exit pupil, great image steadiness because of the 8x magnification, extremely high light transmission because of Leica HDC™ multi-coating and the 56 mm front lens diameter, plus accurate rangefinding. Only 182 mm (3 inches) tall and weighing a mere 1,100 grams (38.8 ounces).



— **LEICA GEOVID 15x56 BRF**

A binocular tailored especially to the needs of long-range shooters, its 15x magnification enables the hunter to discern even the most distant details. Optimal image steadiness is provided by the Leica tripod adapter that is available as an accessory.



With the LEICA GEOVID 8x56 BRF, Leica is expanding the line of Geovid binoculars with a model that is compact and optimized for twilight observation and that has no competition. Images with extremely rich contrast and neutral color rendition and with sharpness to their very edges create a new dimension in observation and in the resolution of the finest details – especially under poor light conditions.

LEICA GEOVID BRF 42 Models – the compact orienteering specialists

The models with the 42 mm front lens diameter not only combine the “observation” with the “rangefinding” functions to optical and electronic perfection – their handiness makes them eminently suitable for a great variety of applications.



— LEICA GEOVID 8 x 42 BRF

The 8 x magnification guarantees a steady image. The combination of a 125 m field of view and precision measurements make the 8 x 42 the compact all-round companion.



— LEICA GEOVID 10 x 42 BRF

The powerful Geovid is well suited for detail-oriented observations and precision measurements over great distances.

A LEICA GEOVID BRF will go with you through thick and thin. This robust product features an aluminum die-cast housing and is nitrogen-filled. Due to the precision engineering of Leica, the LEICA GEOVID BRF will withstand even the most grueling environmental conditions and is waterproof to a depth of 5 m. Thanks to the center hinge and ergonomic design the Geovid is a very compact and space saving product. The comfortable handling will ensure many years of enjoyment.



The Geovid class : Perfect observation and rangefinding

Key features at a glance

- **Premium-performance binocular with integrated laser rangefinder**
Saves time and weight versus using two separate products (binocular and rangefinder).
- **Compact**
Integration of all electrical components into a classic binocular body with center hinge and center focusing device.
- **Robust**
Strong aluminum die-cast housing and soft-touch rubber armoring protect the binocular from damage, while at the same time ensuring secure handling of the product, even when wearing gloves or wet. Functions perfectly under all environmental conditions, from -15 °C to +55 °C (+5 °F to +131 °F), waterproof to 5 m (16.4 ft), nitrogen-filled, impact resistant.
- **Range**
10 – 1,200 m (10 – 1,300 yds)



LEICA GEOVID BRF 56 – observing and rangefinding in poor light conditions.

In black rubber armoring :

15 x 56 BRF, Meter-Version **Order No. 40 035** / Yard-Version **Order No. 40 034**

8 x 56 BRF, Meter-Version **Order No. 40 031** / Yard-Version **Order No. 40 032**



LEICA GEOVID BRF 42 - the compact orienteering specialists.

In black rubber armoring

8 x 42 BRF, Meter-Version **Order No. 40 026** / Yard-Version **Order No. 40 028**

10 x 42 BRF, Meter-Version **Order No. 40 027** / Yard-Version **Order No. 40 029**





The Rangemaster class : Great little rangefinding professionals The laser technology of the Geovid is continued in the compact monocular laser rangefinders of the Leica Rangemaster class : the LEICA RANGEMASTER CRF 1200 and the LEICA RANGEMASTER CRF 900. For nature watchers or golfers who like to travel light without making any sacrifices when it comes to performance, these neat models are ideal. They weigh a mere 220 grams (7.8 oz) (with battery), and offer ranges of approximately 1,100 meters (CRF 1200) and 825 meters (CRF 900). Both Rangemasters offer a scanning mode that displays a continuously updated measurement reading when the release button is kept pressed down. This is particularly useful for small or moving targets and long distances. Further impressive features shared by all two Rangefinders are the brilliant optics, exceptional for this class of product, the 7 x magnification and the integrated diopter compensation.



LEICA RANGEMASTER CRF 900



LEICA RANGEMASTER CRF 1200

LEICA RANGEMASTER CRF 1200 – minimum size, maximum performance For nature watchers who expect a minimum of equipment to deliver a maximum of performance, this handy CRF model is the ultimate solution. With its range of approximately 1,100 meters, it sets completely new standards in the Rangemaster class – while being incredibly compact and lightweight.

— **LEICA RANGEMASTER CRF 1200**

With its high performance and a range of approx. 1,100 m / 1,200 yds, this laser range-finder delivers reliable and accurate readings even in poor weather conditions. Extremely small and lightweight, it disappears into any coat pocket. Its weight of 220 g (less than 8 oz) and dimensions of 113 x 75 x 34 mm (approx. 4½ x 2¼ x 1¼ in) speak for themselves.



Especially bright optics, 7 x magnification and a large field of view provide optimal orientation in the field. The watertight housing provide both Rangemaster models with optimal protection against the harshest weather conditions.

LEICA RANGEMASTER CRF 900 – the reliable companion You can rely on the precision of the CRF 900. With its range of over 825 meters, it delivers accurate measuring results – even in poor weather conditions.

— **LEICA RANGEMASTER CRF 900**

Precision involves many considerations : the high-power laser electronics are securely embedded in the sturdy metal chassis. The watertight, carbon-fiber reinforced housing provides substantial protection. And the automatically dimming LED display provides best reading conditions in every light condition. The result is highest reading precision and enhanced reliability, even in difficult weather conditions.



Exact, quick and straightforward rangefinding for the target in mind – with the Rangemaster CRF 900 you will achieve this objective in any situation.



The Rangemaster class : Great little rangefinding professionals

Key features at a glance

- **Benchmark monocular laser rangefinders**
Light and compact rangefinders for the most varied distances and areas of application.
- **Compact**
The monocular companion that can find room anywhere.
- **Robust**
Carbon-fiber reinforced plastic housing and soft-touch lacquer coating ensure optimal protection while providing minimum weight. Watertight to a depth of 1 meter/yard.
- **Ranges**
LEICA RANGEMASTER CRF 1200 : approx. 10 – 1,100 m (10 – 1,200 yds)
LEICA RANGEMASTER CRF 900 : approx. 10 – 825 m (10 – 902 yds)



LEICA RANGEMASTER CRF 1200 – minimum size, maximum performance.

Meter-Version **Order No. 40 527** / Yard-Version **Order No. 40 523**



LEICA RANGEMASTER CRF 900 – the reliable companion.

Meter-Version **Order No. 40 518** / Yard-Version **Order No. 40 517**





Technical Data

Grey Heron / Ardea cinerea



Binocular	LEICA DUOVID 10 + 15 x 50	LEICA DUOVID 8 + 12 x 42
Order No. Product		
Rubber armored, black	40 420	40 400
Delivery scope	Neoprene carrying strap, contoured, eyepiece cover, Nappa leather case, Tripod adapter	Neoprene carrying strap, contoured, eyepiece cover, Nappa leather case
Magnification	10 x / 15 x	8 x / 12 x
Front lens diameter	50 mm	42 mm
Exit pupil	5.0 mm / 3.3 mm	5.1 mm / 3.5 mm
Twilight factor	22.4 / 27.4	18.33 / 22.5
Field of view at 1,000 m	92 m / 70 m	118 m / 90 m
Field of view at 1,000 yds	274 ft / 208 ft	351 ft / 268 ft
Eye-relief	14.5 mm	14.5 mm
Objective angle of view	5.3° / 4.0°	6.7° / 5.1°
Close focusing distance	approx. 3.7 m / 12.9 ft	approx. 3.5 m / 11.1 ft
Diopter compensation	±3 diopters	±3 diopters
Automatic diopter compensation ADC™	yes	yes
Eyepieces for eyeglass wearers	yes	yes
Adjustable interpupillary distance	59–74 mm	55–74 mm
Sliding Eyecups	yes, removable, with two click stops	yes, removable, with two click stops
Focusing	Internal focusing via central focusing device	Internal focusing via central focusing device
No. of lens elements (each side)	11, all with HDC™ coating	11, all with HDC™ coating
Prism system	Roof prism with phase correcting coating P40 and HighLux-System HLS™	Roof prism with phase correcting coating P40 and HighLux-System HLS™
Watertightness	Watertight to a depth of 5 m / 16.5 ft	Watertight to a depth of 5 m / 16.5 ft
Housing	Die-cast aluminum, nitrogen-filled	Die-cast aluminum, nitrogen-filled
Dimensions (W x H x D)	125 x 192 x 78 mm 4 1/2 x 7 1/2 x 3 1/32 in	123 x 156 x 68 mm 4 3/4 x 6 3/16 x 2 5/8 in
Weight	approx. 1,270 g / 44 oz	approx. 1,045 g / 37 oz
Order No. Accessories		
Neoprene carrying strap, contoured	included	included
Floating carrying strap, orange	-	42 163
Tripod adapter	included	42 220

Technical Data



Binocular	LEICA ULTRAVID 12 x 50 HD	LEICA ULTRAVID 10 x 50 HD	LEICA ULTRAVID 8 x 50 HD
Order No. Product			
Leather design, black	-	-	-
Rubber armored, black	40 297	40 296	40 295
Delivery scope	Neoprene carrying strap, contoured, eyepiece cover, protective front lens cover, Cordura case	Neoprene carrying strap, contoured, eyepiece cover, protective front lens cover, Cordura case	Neoprene carrying strap, contoured, eyepiece cover, protective front lens cover, Cordura case
Magnification	12 x	10 x	8 x
Front lens diameter	50 mm	50 mm	50 mm
Exit pupil	4.2 mm	5 mm	6.2 mm
Twilight factor	24.5	22.4	20
Field of view at 1,000 m	100 m	117 m	117 m
Field of view at 1,000 yds	299 ft	352 ft	352 ft
Eye-relief	13 mm	15 mm	17 mm
Objective angle of view	5.7°	6.7°	6.7°
Close focusing distance	approx. 3.2 m/10.5 ft	approx. 3.3 m/10.8 ft	approx. 3.5 m/11.5 ft
Diopter compensation	±4 diopters	±4 diopters	±4 diopters
Automatic diopter compensation ADC™	yes	yes	yes
Eyepieces for eyeglass wearers	yes, removable, with two click stops	yes, removable, with two click stops	yes, removable, with two click stops
Adjustable interpupillary distance	58–75 mm	58–74 mm	58–74 mm
Focusing	Internal focusing via central focusing device	Internal focusing via central focusing device	Internal focusing via central focusing device
No. of lens elements (each side)	11, all with HDC™ coating and AquaDura™	9, all with HDC™ coating and AquaDura™	8, all with HDC™ coating and AquaDura™
Prism system	Roof prism with phase correcting coating P40 and HighLux-System HLS™	Roof prism with phase correcting coating P40 and HighLux-System HLS™	Roof prism with phase correcting coating P40 and HighLux-System HLS™
Watertightness	Watertight to a depth of 5 m/16.5 ft	Watertight to a depth of 5 m/16.5 ft	Watertight to a depth of 5 m/16.5 ft
Housing	Die-cast magnesium, nitrogen-filled	Die-cast magnesium, nitrogen-filled	Die-cast magnesium, nitrogen-filled
Dimensions (W x H x D)	120 x 182 x 78 mm 4 ¾ x 7 ⅛ x 2 ¾ in	125 x 178 x 70 mm 4 7/8 x 7 x 2 ¾ in	120 x 182 x 68 mm 4 ¾ x 7 ⅛ x 2 ¾ in
Weight	approx. 1,040 g/36.7 oz	approx. 1,000 g/35.3 oz	approx. 1,000 g/35.3 oz
Order No. Accessories			
Neoprene carrying strap, contoured	included	included	included
Floating carrying strap, orange	42 163	42 163	42 163
Tripod adapter	42 220	42 220	42 220

LEICA ULTRAVID
10 x 42 HD/BL
LEICA ULTRAVID
8 x 42 HD/BL
LEICA ULTRAVID
7 x 42 HD

40 272

40 271

-

40 294

40 293

40 292

HD : Neoprene carrying strap, contoured, eyepiece cover, protective front lens cover, Cordura case

BL : Leather carrying strap, contoured, eyepiece cover, deep-drawn leather case

HD : Neoprene carrying strap, contoured, eyepiece cover, protective front lens cover, Cordura case

BL : Leather carrying strap, contoured, eyepiece cover, deep-drawn leather case

Neoprene carrying strap, contoured, eyepiece cover, protective front lens cover, Cordura case

10 x

8 x

7 x

42 mm

42 mm

42 mm

4.2 mm

5.2 mm

6 mm

20.5

18.3

17.1

112 m

130 m

140 m

336 ft

389 ft

420 ft

16 mm

15.5 mm

17 mm

6.4°

7.4°

8°

approx. 2.9 m/9.5 ft

approx. 3 m/9.8 ft

approx. 3.3 m/10.8 ft

±4 diopters

±4 diopters

±4 diopters

yes

yes

yes

yes, removable, with two click stops

yes, removable, with two click stops

yes, removable, with two click stops

55–75 mm

55–75 mm

55–75 mm

Internal focusing via central focusing device

Internal focusing via central focusing device

Internal focusing via central focusing device

9, all with HDC™ coating and AquaDura™ (AquaDura™ only for HD)

9, all with HDC™ coating and AquaDura™ (AquaDura™ only for HD)

8, all with HDC™ coating and AquaDura™

Roof prism with phase correcting coating P40 and HighLux-System HLS™

Roof prism with phase correcting coating P40 and HighLux-System HLS™

Roof prism with phase correcting coating P40 and HighLux-System HLS™

Watertight to a depth of 5 m/16.5 ft

Watertight to a depth of 5 m/16.5 ft

Watertight to a depth of 5 m/16.5 ft

Die-cast magnesium, nitrogen-filled

Die-cast magnesium, nitrogen-filled

Die-cast magnesium, nitrogen-filled

HD : 120 x 147 x 68 mm

4 ¾ x 5 ¾ x 2 ¾ in

BL : 120 x 146 x 62 mm

4 ¾ x 5 ¾ x 2 ½ in

HD : 121 x 142 x 67 mm

4 ¾ x 5 ⅝ x 2 ⅝ in

BL : 121 x 141 x 63 mm

4 ¾ x 5 ⅝ x 2 ½ in

120 x 141 x 68 mm

4 ¾ x 5 ⅝ x 2 ⅝ in

approx. 770 g/27.2 oz

HD : approx. 750 g/26.5 oz

BL : approx. 695 g/24.7 oz

HD : approx. 790 g/27.9 oz

BL : approx. 710 g/25 oz

included (HD)

included (HD)

included

42 163

42 163

42 163

42 220

42 220

42 220

Technical Data



Binocular	LEICA ULTRAVID 10x32 HD	LEICA ULTRAVID 8x32 HD	LEICA ULTRAVID 10x25 BR/BL	LEICA ULTRAVID 8x20 BR/BL
Order No. Product				
Leather design, black	-	-	40 257	40 256
Rubber armored, black	40 291	40 290	40 253	40 252
Delivery scope	Neoprene carrying strap, contoured, eyepiece cover, protective front lens cover, Cordura case	Neoprene carrying strap, contoured, eyepiece cover, protective front lens cover, Cordura case	BR : Woven carrying strap, eyepiece cover, Cordura case with belt loop BL : Woven carrying strap, eyepiece cover, deep-drawn leather case	BR : Woven carrying strap, eyepiece cover, Cordura case with belt loop BL : Woven carrying strap, eyepiece cover, deep-drawn leather case
Magnification	10x	8x	10x	8x
Front lens diameter	32 mm	32 mm	25 mm	20 mm
Exit pupil	3.2 mm	4 mm	2.5 mm	2.5 mm
Twilight factor	17.9	16	15.8	12.7
Field of view at 1,000 m	118 m	135 m	90 m	113 m
Field of view at 1,000 yds	352 ft	404 ft	273 ft	341 ft
Eye-relief	13.2 mm	13.3 mm	15 mm	16 mm
Objective angle of view	6.7°	7.7°	5.2°	6.5°
Close focusing distance	approx. 2 m/6.6 ft	approx. 2.1 m/6.9 ft	approx. 3.2 m/ 10.5 ft	approx. 1.8 m/7.2 ft
Diopter compensation	±4 diopters	±4 diopters	±3.5 diopters	± 3.5 diopters
Automatic diopter compensation ADC™	yes	yes	yes	yes
Eyepieces for eyeglass wearers	yes, removable, with two click stops	yes, removable, with two click stops	yes	yes
Adjustable interpupillary distance	52–74 mm	52–74 mm	34–74 mm	34–74 mm
Focusing	Internal focusing via central focusing device	Internal focusing via central focusing device	Internal focusing via central focusing knob	Internal focusing via central focusing knob
No. of lens elements (each side)	11, all with HDC™ coating and AquaDura™	9, all with HDC™ coating and AquaDura™	6, all with HDC™ coating	6, all with HDC™ coating
Prism system	Roof prism with phase correcting coating P40 and HighLux-System HLS™	Roof prism with phase correcting coating P40 and HighLux-System HLS™	Roof prism with phase correcting coating P40 and HighLux-System HLS™	Roof prism with phase correcting coating P40 and HighLux-System HLS™
Watertightness	Watertight to a depth of 5 m/ 16.5 ft	Watertight to a depth of 5 m/ 16.5 ft	Watertight to a depth of 5 m/ 16.5 ft	Watertight to a depth of 5 m/ 16.5 ft
Housing	Magnesium, nitrogen-filled	Magnesium, nitrogen-filled	Aluminum, nitrogen-filled	Aluminum, nitrogen-filled
Dimensions (W x H x D)	116 x 120 x 56 mm 4 5/8 x 4 3/4 x 2 1/4 in	116 x 116 x 56 mm 4 5/8 x 4 5/8 x 2 1/4 in	111 x 112 x 39 mm 4 3/8 x 4 3/8 x 1 1/2 in	111 x 93 x 39 mm 4 3/8 x 3 3/8 x 1 1/2 in
Weight	approx. 565 g/ 19.9 oz	approx. 535 g/ 18.9 oz	BR : approx. 265 g/9.4 oz BL : approx. 255 g/9.0 oz	BR : approx. 240 g/8.5 oz BL : approx. 230 g/8.1 oz
Order No. Accessories				
Neoprene carrying strap, contoured	included	included	-	-
Floating carrying strap, orange	42 163	42 163	-	-
Tripod adapter	42 220	42 220	-	-



Binocular	LEICA TRINOVID 10 x 25 BCA	LEICA TRINOVID 8 x 20 BCA
Order No. Product		
Rubber armored, black	40 343	40 342
Delivery scope	Carrying cord, Cordura case with belt loop	Carrying cord, Cordura case with belt loop
Magnification	10 x	8 x
Front lens diameter	25 mm	20 mm
Exit pupil	2.5 mm	2.5 mm
Twilight factor	15.8	12.65
Field of view at 1,000 m	90 m	113 m
Field of view at 1,000 yds	273 ft	341 ft
Eye-relief	14.6 mm	14 mm
Objective angle of view	5.2°	6.5°
Close focusing distance	approx. 5 m/16.4 ft	approx. 3 m/9.8 ft
Diopter compensation	±3.5 diopters	±3.5 diopters
Eyepieces for eyeglass wearers	yes	yes
Sliding Eyecups	extendable eyecups	extendable eyecups
Adjustable interpupillary distance	32–74 mm	32–74 mm
Focusing	Internal focusing via central focusing knob	Internal focusing via central focusing knob
No. of lens elements (each side)	6, all with HDC™ coating	6, all with HDC™ coating
Prism system	Roof prism with phase correcting coating P40	Roof prism with phase correcting coating P40
Watertightness	Waterspray resistant	Waterspray resistant
Housing	Aluminum, nitrogen-filled	Aluminum, nitrogen-filled
Dimensions (W x H x D)	110 x 92 x 37 mm 4 3/8 x 3 5/8 x 1 1/2 in	96 x 92 x 37 mm 3 3/4 x 3 5/8 x 1 1/2 in
Weight	approx. 255 g/9.0 oz	approx. 235 g/8.3 oz
Order No. Accessories		
Neoprene carrying strap, contoured	-	-
Floating carrying strap, orange	-	-
Tripod adapter	-	-

Technical Data



Spotting scope	LEICA TELEVID 82 HD	LEICA APO-TELEVID 82
Order no. Product		
Straight viewing	40 118	40 119
Angled viewing (45°)	40 120	40 121
Delivery scope	20 – 60 x eyepiece, front and rear caps	25 – 50 x WW eyepiece, front and rear caps
Front lens diameter	82 mm	82 mm
Focal length of the lens	approx. 440 mm	approx. 440 mm
Close focusing distance	approx. 3.9 m/12.8 ft	approx. 3.9 m/12.8 ft
Exit pupil, twilight factor and field of view	See eyepiece chart	See eyepiece chart
Focusing	Internal focusing with patented dual focusing device	Internal focusing with patented dual focusing device
No. of lens elements (excluding the eyepiece)	4, all multi-coated and AquaDura™	4, all multi-coated and AquaDura™
Prism system		
Straight viewing	Schmidt Pechan prism system	Schmidt Pechan prism system
Angled viewing (45°)	Schmidt Prism System	Schmidt Prism System
Watertightness	Watertight to a depth of 5 m/17 ft	Watertight to a depth of 5 m/17 ft
Housing	Die-cast magnesium, nitrogen-filled	Die-cast magnesium, nitrogen-filled
Eyepiece connection	Rapid-change bayonet	Rapid-change bayonet
Tripod base	1/4", rotating with locking screw	1/4", rotating with locking screw
Lens hood	Sliding lens hood with sighting aid	Sliding lens hood with sighting aid
Filter thread mount	E82	E82
Dimensions (W x H x D)	108 x 310 x 93 mm / 4 1/4 x 12 3/16 x 3 19/32 in straight ; 108 x 325 x 93 mm / 4 1/4 x 12 19/16 x 3 19/32 in angled	108 x 310 x 93 mm / 4 1/4 x 12 3/16 x 3 19/32 in straight ; 108 x 325 x 93 mm / 4 1/4 x 12 19/16 x 3 19/32 in angled
Weight	approx. 1,350 g/47.7 oz	approx. 1,350 g/47.7 oz
Order No. Accessories		
Eyepiece 32 x WW	41 016	41 016
Zoom eyepiece 20 – 60 x	41 018	41 018
Zoom eyepiece 25 – 50 x WW ASPH.	41 019	41 019
Photo adapter 1:12.2/800mm	42 306	42 306
T2 adapter for Leica R system	42 305	42 305
Digitaladapter 3	42 304	42 304
Cordura ever-ready case		
for straight viewing scope	42 314	42 314
for angled viewing scope	42 313	42 313



Spotting scope	LEICA TELEVID 65 HD	LEICA APO-TELEVID 65
Order no. Product		
Straight viewing	40 126	40 127
Angled viewing (45°)	40 128	40 129
Delivery scope	20 – 60x eyepiece, front and rear caps	25 – 50x WW eyepiece, front and rear caps
Front lens diameter	65 mm	65 mm
Focal length of the lens	approx. 440 mm	approx. 440 mm
Close focusing distance	approx. 3.2 m/10.5 ft	approx. 3.0 m/9.8 ft
Exit pupil, twilight factor and field of view	See eyepiece chart	See eyepiece chart
Focusing	Internal focusing with patented dual focusing device	Internal focusing with patented dual focusing device
No. of lens elements (excluding the eyepiece)	4, all multi-coated and AquaDura™	4, all multi-coated and AquaDura™
Prism system		
Straight viewing	Schmidt Pechan prism system	Schmidt Pechan prism system
Angled viewing (45°)	Schmidt Prism System	Schmidt Prism System
Watertightness	Watertight to a depth of 5 m/ 17 ft	Watertight to a depth of 5 m/ 17 ft
Housing	Die-cast magnesium, nitrogen-filled	Die-cast magnesium, nitrogen-filled
Eyepiece connection	Rapid-change bayonet	Rapid-change bayonet
Tripod base	1/4", rotating with locking screw	1/4", rotating with locking screw
Lens hood	Sliding lens hood with sighting aid	Sliding lens hood with sighting aid
Filter thread mount	E67	E67
Dimensions (W x H x D)	108 x 277 x 83 mm/4 1/4 x 10 29/32 x 3 3/16 in straight; 108 x 300 x 83 mm/4 1/4 x 11 13/16 x 3 3/16 in angled	108 x 277 x 83 mm/4 1/4 x 10 29/32 x 3 3/16 in straight; 108 x 300 x 83 mm/4 1/4 x 11 13/16 x 3 3/16 in angled
Weight	approx. 1,050 g/37.1 oz	approx. 1,100 g/38.8 oz
Order No. Accessories		
Eyepiece 32 x WW	41 016	41 016
Zoom eyepiece 20 – 60 x	41 018	41 018
Zoom eyepiece 25 – 50 x WW ASPH.	41 019	41 019
Photo adapter 1:12.2/800mm	42 306	42 306
T2 adapter for Leica R system	42 305	42 305
Digitaladapter 3	42 304	42 304
Cordura ever-ready case		
for straight viewing scope	42 312	42 312
for angled viewing scope	42 311	42 311

Technical Data



	32 x WW	20 – 60x (Zoom)	25 – 50 x WW ASPH.
Eyepiece for LEICA TELEVID 82			
Order No. Product	41 016	41 018	41 019
No. of lens elements	7 elements	9 elements	8 elements
Magnification	32x	20 – 60x	25 – 50x
Focal length	14 mm	22.2 – 7.3 mm	18 – 9 mm
Exit pupil	2.56 mm	4.1 – 1.4 mm	3.28 – 1.64 mm
Angle of view	2.3°	2.0° – 1.2°	2.35° – 1.6°
Field of view at 1,000m/yds	40 m/131 ft	34 – 20 m/112 – 65 ft	41 – 28 m/34 – 92 ft
Eye relief	20 mm	19 mm	19 mm
Length	68 mm	83 mm	100 mm
Diameter	56.5 mm	56.5 mm	57.5 mm
Weight	approx. 288 g/10 oz	approx 320 g/11.2 oz	approx. 390 g/13.7 oz



	32 x WW	20 – 60x (Zoom)	25 – 50 x WW ASPH.
Eyepiece for LEICA TELEVID 65			
Order No. Product	41 016	41 018	41 019
No. of lens elements	7 elements	9 elements	8 elements
Magnification	32x	20 – 60x	25 – 50x
Focal length	14 mm	22.2 – 7.3 mm	18 – 9 mm
Exit pupil	2.03 mm	3.25 – 1.08 mm	2.6 – 1.3 mm
Angle of view	2.3°	2.0° – 1.2°	2.35° – 1.6°
Field of view at 1,000m/yds	40 m/131 ft	34 – 20 m/112 – 65 ft	41 – 28 m/134 – 92 ft
Eye relief	20 mm	19 mm	19 mm
Length	68 mm	83 mm	100 mm
Diameter	56.5 mm	56.5 mm	57,5 mm
Weight	approx. 288 g/10 oz	approx 320 g/11.2 oz	approx. 390 g/13.7 oz

Photo Adapter 800

Order No. 42 306

Focal Length 800 mm

Speed

with LEICA TELEVID 82 1:9.8

with LEICA TELEVID 65 1:12.2



	LEICA GEOVID 15 x 56 BRF	LEICA GEOVID 8 x 56 BRF
Order No. Product	40 035 (Meter-Version) 40 034 (Yard-Version)	40 031 (Meter-Version) 40 032 (Yard-Version)
Delivery scope	Neoprene carrying strap, eyepiece cover, protective front lens cover, battery, Cordura case	Neoprene carrying strap, eyepiece cover, protective front lens cover, battery, Cordura case
Magnification	15 x	8 x
Front lens diameter	56 mm	56 mm
Exit pupil	3.7 mm	7 mm
Twilight factor	28.2	21.2
Field of view at 1,000 m	75 m	118 m
Field of view at 1,000 yds	225 ft	357 ft
Eye-relief	15.5 mm	18.5 mm
Objective angle of view	4.3°	6.8°
Close focusing distance	approx. 5.9 m/19.45 ft	approx. 5.6 m/18.4 ft
Diopter compensation	±4 diopters	±3.5 diopters
Distance measurement		
Range	10 m to approx. 1,200 m/10 yds to approx. 1,300 yds	10 m to approx. 1,200 m/10 yds to approx. 1,300 yds
Accuracy	±1 m/yd up to 366 m/400 yds ±2 m/yds up to 732 m/800 yds ±0.5% beyond 732 m/800 yds	±1 m/yd up to 350 m/380 yds ±2 m/yds up to 700 m/763 yds ±0.5% beyond 700 m/763 yds
Read-outs	LED display with four digits, easily legible in any light	LED display with four digits, easily legible in any light
Eyepieces for eyeglass wearers	yes	yes
Sliding eyecups	yes, removable, with two click stops	yes, removable, with two click stops
Adjustable interpupillary distance	56–74 mm	56–74 mm
Focusing	Internal focusing via central focusing device	Internal focusing via central focusing device
No. of lens elements (each side)	7, all with HDC™ coating	7, all with HDC™ coating
Prism system	Roof prism with phase correction coating P40	Roof prism with phase correction coating P40
Watertightness	Watertight to a depth of 5 m/16.5 ft	Watertight to a depth of 5 m/16.5 ft
Housing	Die-cast aluminum, nitrogen-filled	Die-cast aluminum, nitrogen-filled
Dimensions (W x H x D)	134 x 210 x 70 mm/5 1/4 x 7 1/8 x 2 5/8 in	135 x 182 x 68 mm/5 1/4 x 7 1/8 x 2 5/8 in
Weight	approx. 1,300 g/45.9 oz incl. batteries	approx. 1,100 g/38.8 oz incl. batteries
Meter/Yard selector	no	no
Laser	Eye-safe invisible laser according to EN and FDA class 1	Eye-safe invisible laser according to EN and FDA class 1
Laser beam divergence	2.5 x 0.5 mrad	2.5 x 0.5 mrad
Measuring time	max. approx. 1.4 s	max. approx. 1.4 s
Measuring mode	Scanning mode	Scanning mode
Power supply	1 x 3V/Lithium-type C2R	1 x 3V/Lithium-type C2R
Battery lifetime	approx. 2,000 measurements at 20 °C/68 °F	approx. 2,000 measurements at 20 °C/68 °F
Order No. Accessories		
Neopren carrying strap, contoured	included	included
Floating carrying strap, orange	42 163	42 163
Tripod adapter	42 220	42 220

Technical Data



Binocular	LEICA GEOVID 10 x42 BRF	LEICA GEOVID 8 x42 BRF
Order No. product	40 027 (Meter-Version) 40 029 (Yard-Version)	40 026 (Meter-Version) 40 028 (Yard-Version)
Delivery Scope	Neoprene carrying strap, eyepiece cover, protective front lens cover, battery, Cordura case	Neoprene carrying strap, eyepiece cover, protective front lens cover, battery, Cordura case
Magnification	10 x	8 x
Front lens diameter	42 mm	42 mm
Exit pupil	4.2 mm	5.3 mm
Twilight factor	20.5	18.3
Field of view at 1,000 m	110 m	125 m
Field of view at 1,000 yds	331 ft	368 ft
Eye-relief	15.6 mm	18 mm
Objective angle of view	6.3°	7°
Close focusing distance	approx. 5.6 m/ 18.4 ft	approx. 5.6 m/ 18.4 ft
Diopter compensation	±3.5 diopters	±3.5 diopters
Distance measurement		
Range	10 m to approx. 1,200 m/ 10 yds to approx. 1,300 yds	10 m up to approx. 1,200 m/ 10 yds to approx. 1,300 yds
Accuracy	±1 m/ yd up to 350 m/380 yds ±2 m/ yds up to 700 m/763 yds ±0.5% beyond 700 m/763 yds	±1 m/ yd up to 350 m/380 yds ±2 m/ yds up to 700 m/763 yds ±0.5% beyond 700 m/763 yds
Read-outs	LED display with four digits, easily legible in any light	LED display with four digits, easily legible in any light
Eyepieces for eyeglass wearers	yes	yes
Sliding eyecups	yes, removable, with two click stops	yes, removable, with two click stops
Adjustable interpupillary distance	56–74 mm	56–74 mm
Focusing	Internal focusing via central focusing device	Internal focusing via central focusing device
No. of lens elements (each side)	7, all with HDC™ coating	7, all with HDC™ coating
Prism system	Roof prism with phase correction coating P40	Roof prism with phase correction coating P40
Watertightness	Watertight to a depth of 5 m/ 16.5 ft	Watertight to a depth of 5 m/ 16.5 ft
Housing	Die-cast aluminium, nitrogen-filled	Die-cast aluminium, nitrogen-filled
Dimensions (W x H x D)	125 x 168 x 70 mm/ 4 7/8 x 6 5/8 x 2 3/4 in	125 x 173 x 70 mm/ 4 7/8 x 6 3/4 x 2 3/4 in
Weight	approx. 945 g/33.3 oz incl. batteries	approx. 950 g/33.5 oz incl. batteries
Meter /Yard selector	no	no
Laser	Eye-safe invisible laser according to EN and FDA class 1	Eye-safe invisible laser according to EN and FDA class 1
Laser beam divergence	2.5 x 0.5 mrad	2.5 x 0.5 mrad
Measuring time	max. approx. 1.4 s	max. approx. 1.4 s
Measuring mode	Scanning mode	Scanning mode
Power supply	1 x 3 V/Lithium-type C2R	1 x 3 V/Lithium-type C2R
Battery lifetime	approx. 2,000 measurements at 20 °C/68 °F	approx. 2,000 measurements at 20 °C/68 °F
Order No. Accessories		
Neopren carrying strap, contoured	included	included
Floating carrying strap, orange	42 163	42 163
Tripod adapter	42 220	42 220



Product	LEICA RANGEMASTER CRF 1200	LEICA RANGEMASTER CRF 900
Order No. Product	40 527 (Meter-Version) 40 523 (Yard-Version)	40 518 (Meter-Version) 40 517 (Yard-Version)
Delivery scope	Carrying cord, battery, Cordura case	Carrying cord, battery, Cordura case
Magnification	7 x	7 x
Front lens diameter	24 mm	24 mm
Exit pupil	3.4 mm	3.4 mm
Twilight factor	13	13
Field of view at 1,000 m	115 m	115 m
Field of view at 1,000 yds	347 ft	347 ft
Eye-relief	15 mm	15 mm
Objective angle of view	6.6°	6.6°
Diopter compensation	±3.5 diopters	±3.5 diopters
Distance measurement		
Range	10 to 1,100 m 10 to 1,200 yds	10 to approx. 825 m 10 to 902 yds
Accuracy	±1 m/yd to 366 m/400 yds ±2 m/yds to 732 m/800 yds ±0,5% over 732 m/800 yds	±1 m/yds to 366 m/400 yds ±2 m/yds to 732 m/800 yds ±0,5% over 732 m/800 yds
Read-outs	LED display with four digits, easily legible in any light	LED display with four digits, easily legible in any light
Eyepieces for eyeglass wearers	yes	yes
Eyecups	turn down rubber eyecups	turn down rubber eyecups
Prism system	Roof prism with phase correction coating P40	Roof prism with phase correction coating P40
Watertightness	Watertight to a depth of 1 m/3.2 ft	Watertight to a depth of 1 m/3.2 ft
Housing	Carbon fiber-reinforced plastic material	Carbon fiber-reinforced plastic material
Dimensions (W x H x D)	113 x 75 x 34 mm 4 ½ x 2 ¼ x 1 ¼ in	113 x 75 x 34 mm 4 ½ x 2 ¼ x 1 ¼ in
Weight	approx. 220 g/7.8 oz incl. battery	approx. 220 g/7.8 oz incl. battery
Meter/Yard Selector	no	no
Laser	Eye-safe invisible laser according to EN and FDA class 1	Eye-safe invisible laser according to EN and FDA class 1
Laser beam divergence	approx. 2.5 x 0.5 mrad	approx. 2.5 x 0.5 mrad
Measuring time	maximum approx. 0.85 s	maximum approx. 0.85 s
Measuring mode	Scanning mode	Scanning mode
Power supply	1 x 3 V/Lithium-type C2R	1 x 3 V/Lithium-type C2R
Battery lifetime	approx. 2,000 measurements at 20 °C/68 °F	approx. 2,000 measurements at 20 °C/68 °F

Very useful observation equipment

Practical accessories for more convenient observation of the nature

Included in the delivery scope and available as a replacement



Nappa leather case
for Duovid 42 and 50



Deep-drawn leather case
for Ultravid BL 42



Deep-drawn leather case with belt loop
for Ultravid BL 20 and 25



Cordura case
for Ultravid HD 32, 42 and 50,
Geovid BRF 42 and 56



Cordura case with belt loop
for Ultravid BR 20 and 25, Trinovid BCA 20
and 25, Rangemaster CRF 1200 and 900



Contoured Leather carrying strap for Ultravid BL 42



Contoured Neoprene carrying strap
for Duovid 42 and 50, Ultravid HD 32, 42 and 50, Ultravid HD/BL 42,
Geovid BRF 42 and 56

Carrying cord

for Trinovid BCA 20 and 25

Woven carrying strap

for Ultravid BR 20 and 25, Ultravid BL 20 and 25

Front caps for all Ultravids and Geovids

Protective front lens cover for all Televids

Eyepiece cover for all Duovids, Ultravids, Geovids and Trinovids

Rear caps for all Televids

You can complete your products with the following accessories :



Floating carrying strap, orange
for Ultravid HD 32, Ultravid HD/BL 42, Ultravid HD 50, Geovid BRF 42
Order No. 42 163



Contoured Neoprene carrying strap
for Duovid 42 and 50, Ultravid HD 32, 42 and 50, Ultravid HD/BL 42,
Geovid BRF 42 and 56
Order No. 42 146



Tripod Adapter for binoculars

for Duovid 42 and 50, Ultravid HD 32 and 50, Ultravid HD/BL 42, Geovid BRF 42 and 56

Order No. 42 220



Ever-ready-case for Televid 82 straight view

for Televid HD and APO-Televid 82 straight view

Order No. 42 314



Ever-ready-case for Televid 82 angled view

for Televid HD and APO-Televid 82 angled view

Order No. 42 313

Ever-ready-case for Televid 65 angled view

for Televid HD and APO-Televid 65 angled view

Order No. 42 311

Ever-ready-case for Televid 62 straight view

for Televid HD and APO Televid 65 straight view

Order No. 42 312



Photo Adapter for 82 mm spotting scopes 1:9,8/800 mm

Photo Adapter for 65 mm spotting scopes 1:12,2/800 mm

for all Televids

Order No. 42 306

Digital Adapter 3

for all Televids

Order No. 42 304

T2 Adapter for the Leica R system for all Televids

Order No. 42 305



Glossary We hope that the following glossary of main terms and quality criteria for the evaluation of binoculars and spotting scopes will be helpful to you in making a purchasing decision. In addition, here are authorized Leica dealers and representatives around the world who will be pleased to assist you. They have a large selection of products and they will gladly present you your favorite model.

Technical binocular terms

Magnification Every binocular is specified by two numbers, of which the first one always indicates the magnification. Magnification tells us how much closer an object appears to the observer when viewed through the binocular. For example : At 8x magnification, a bird that is 328 feet/100 m away appears to be only 41 feet/12.5 m (328 ft : 8 = 41 ft) away.

Front lens diameter The second characteristic number of a binocular is the front lens diameter (the entry pupil of the binocular) stated in millimeters. A binocular with the designation 10x50 has a front lens diameter of 50 mm. The larger the front lens diameter, the more light can be gathered by the binocular. If observation is to be conducted at twilight or at night, the ideal choice is a front lens diameter of 42 or 50 mm. Binoculars with a front lens diameter of 20 to 32 mm are suited primarily for observation in daylight.



Exit pupil The two bright circular areas that can be seen when one looks at the eyepiece of a binocular from a distance of approximately 12 inches/30 cm. (Exit pupil = front lens diameter in mm : magnification factor). An indication of quality is that these areas should be exactly circular and that they should have sharp edges. The pupil of the eye changes its diameter in accordance with the light intensity (small in bright light, large in the dark). For example, a 40-year old observer typically has a maximal pupil diameter of 6 mm. A rule of thumb for comfortable observation is that the exit pupil of a binocular should be at least as large as the pupil of the eye at its largest diameter. The exit and entry pupils are not, however, the only decisive quality characteristics for the evaluation of image brightness : Factors such as contrast, resolving power and light transmission of a binocular or spotting scope are just as important.

Twilight factor The twilight factor is a computed number that describes the theoretical performance capability of a binocular at twilight. It is computed by taking the square root of the product of the magnification factor and the front lens diameter. The twilight factor is a purely mathematical value that says nothing about the optical quality of a binocular, such as contrast, neutral color rendition, resolving power, etc.

Example LEICA TRINOVID 10 x 42 BN

Magnification = 10x, front lens diameter = 42 mm

$$\text{Exit pupil} = \frac{\text{front lens diameter}}{\text{magnification}} = 4.2 \text{ mm}$$

$$\text{Twilight factor} = \sqrt{\text{front lens diameter} \times \text{magnification factor}} = 20.5$$

Objective field of view This value defines the width of the field of view at a distance of 1,000 meters. Usually, the greater the magnification, the smaller the field of view. Binoculars with a large field of view enable the observer to cover a large area and to follow moving subjects, such as a flock of birds, conveniently. A significant quality criterion of Leica binoculars is an image that is a field of view that is crisp and sharp to its very edges and that is rich in contrast.



Glossary For illustration purposes, the pictorial examples show strongly exaggerated effects of the various types of imaging errors or aberrations.

Optical quality

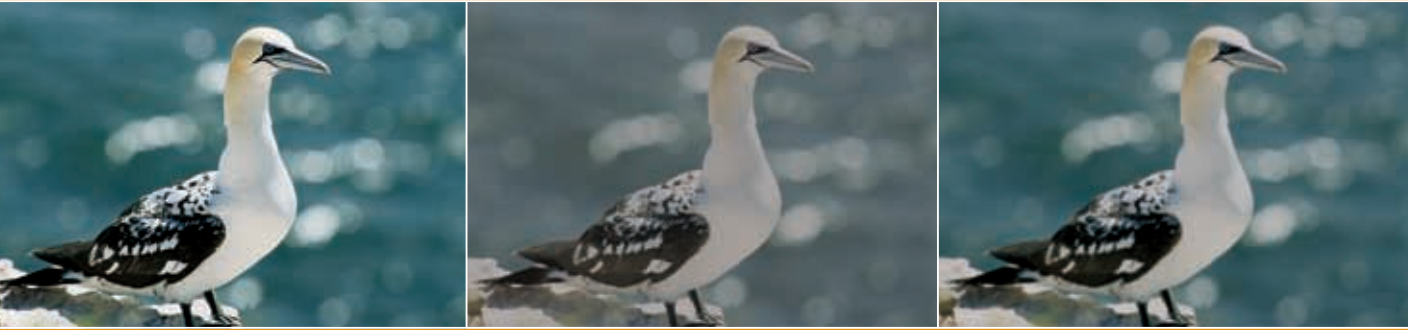

Contrast and resolving power **Contrast** is defined as the difference in brightness between light and dark areas of the image. The greater this difference, the higher the contrast. An image that is rich with contrast is subjectively perceived to be sharper and more brilliant. **Resolving power** is the extent to which an optical system is capable of reproducing the finest structures. The greater the resolving power, the better are the finest details rendered, even under difficult light conditions. Pictorial examples : In optimally rendered images (left), both contrast and resolution are high. If the contrast is too low, the image is flat (center). If the resolution is too low, the image is unsharp, one can no longer discern details in the feathers (right).

Reflections and flare When light rays are reflected by lens surfaces and/or structural components or scattered by lens mounts, they arrive at a location in the image that is different from the one where they are intended to arrive. Undesired reflections and light areas that can degrade the image significantly and that can impair the visual impression occur especially when the sun shines directly into the front lens. To prevent reflections and flare caused by stray light rays, Leica takes numerous dedicated steps. To begin with, the shapes of lens surfaces, mounting components and light traps are already optimized during the design stage so that no extremely disturbing effects are to be expected. Furthermore, a significant reduction in reflections and stray light components is achieved by means of special coatings of lens elements (vapor deposition of special reflection-reducing layers) and by the matte black finish of internal mechanical components.

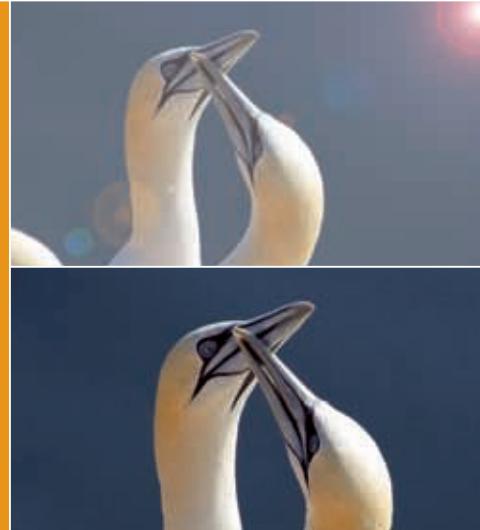

Depth of field Depth of field is the distance between the nearest and the furthest away objects that can still be perceived as being sharp at a given focus setting without the need for refocusing. The depth of field is dependent upon the magnification of a binocular or spotting scope. The lower the magnification, the greater the depth of field. Therefore, if one wishes to see several objects at different distances but with the same sharpness (as illustrated on the left), one would give preference to a binocular with a 7 x or 8 x magnification, which would also have great advantages for observation at twilight or in poor light conditions, because one would not have to keep refocusing to maintain a sharp image. The greater the magnification, the smaller the depth of field. Greater magnifications are advantageous when one wishes to discern more details or smaller objects, as illustrated on the right.

Imaging errors (aberrations) In order for a sharp image to be created, light from a point on the subject must reconverge as a point in the picture. As a rule, a single lens element is not adequate for this purpose, because it has inherent deviations (imaging errors or aberrations), that are described as follows : By selecting appropriate types of optical glass and lens coatings, and by combining the right lens elements and by converting the computed lens design into reality as accurately as possible, Leica succeeds in keeping all the residual aberrations at a very low level. To that end all phases, from optical design to fabrication, are optimized for the always highest possible imaging quality.

Aperture errors – spherical aberration The closer to the edge light rays pass through a lens, the more they will tend to arrive away from the actual picture point. Because this effect becomes stronger as the front lens diameter increases, it is referred to as aperture error, also called spherical aberration. Aperture error causes a loss of sharpness and contrast in the image. In extreme cases, flare becomes noticeable – halos are formed around point sources of light, as illustrated in the pictorial example above.

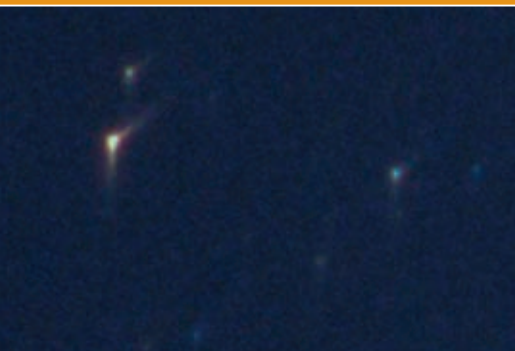

Coma When coma is present, light rays will deviate to one side of their intended picture point. The picture point will gain a tail like a comet. This effect occurs more towards the edges of the picture and not in its center. Strong coma leads to a loss in sharpness and contrast, in extreme cases the coma tail becomes noticeable in point sources of light, as illustrated in the enlarged section of a picture of a star. This section was cropped from the left upper corner of the moon picture.



Glossary

Astigmatism Because of the naturally curved shape of a lens, not all light rays converge on the same plane. While the center of the picture is sharp, the edge of the picture appears to be out of focus. One can cause objects in one or the other plane to be rendered sharply by refocusing. In addition, astigmatism causes the sharpness of an object detail to be influenced by its orientation. This effect becomes stronger towards the edges of the image. For example, if we look at the corner of a picture of a chain link fence, it will be noticeable (if astigmatism is present) that the wires that point towards the center of the image are reproduced with a different degree of sharpness than those that are oriented at a right angle to them. By refocusing, one or the other wire direction can be rendered sharply, but not both of them at the same time. This effect can be reduced by appropriate optical design measures, but it cannot be eliminated completely. Astigmatism leads to a significant impairment of the image quality.



Distortion The term distortion is used to describe the effect that causes the image of an object to be rendered with a non-uniform reproduction ratio. For binocular observation, unlike in photography, this effect is applied quite deliberately to reduce the so-called “globe effect” caused by perspective observation and by swinging the binocular. To the observer, the image created in this manner appears straightened out. There are two kinds of distortion : pincushion distortion (illustrated on the top), and barrel distortion (as shown on the bottom). Observation through a binocular that does not have deliberately implemented judicious distortion is quite unpleasant.

Leica AquaDura™ coating To improve performance when observing, especially in poor weather conditions, Leica has developed a new, innovative coating – Leica AquaDura™. It is modeled on something found in nature : in the lotus plant, for example, whose leaves never get dirty and droplets of water simply roll off them. How does this happen ? Liquids tend to form spherical shapes due to cohesion (stabilizing forces within the liquid). If droplets of water come into contact with a surface, its cohesive forces are counteracted by the adhesive forces on the surface. Depending on the composition of the surface and the surface tension, it can result in the surface becoming totally wet. This is precisely where Leica AquaDura™ comes into play : The coating alters the surface structure of the outer optical glass surfaces in such a way that the adhesive forces are reduced to a minimum (see illustration). As a result, liquids no longer have any adhesion and “roll” off the surface. In doing so, they take dirt and grease, such as fingerprints, with them and enable clearer visibility.

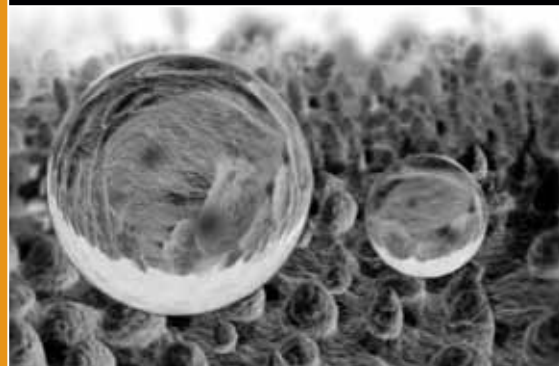

Color errors (chromatic aberrations) Every image-forming component made of glass – such as lens elements – refracts light rays of different colors at different angles. This results in the fact that not all the light rays that emanate from a multi-colored point on the object are re-united at a single point in the image. This results in color errors for the observer. Color errors become particularly evident to the observer as color fringes when high magnifications and long focal lengths are being used, as they are in spotting scopes. Pictorial examples : Color errors appear primarily as color fringes around dark objects in front of bright backgrounds, as illustrated by the example on the left with the red-fringed feather dress. With APO correction of Leica (right illustration) such color effects are no longer discernible.

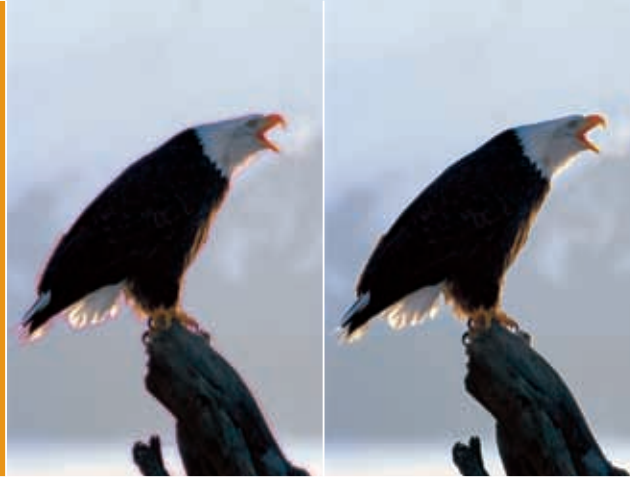

Optical glasses with anomalous partial dispersion Light rays of different colors are refracted at different angles through the lens elements. This effect is called dispersion and in different types of glass it is present at different levels of strength. Most types of glass have typical, “normal” characteristics. Special glasses with “anomalous partial dispersion”, on the other hand, have characteristics that are different in certain ranges of colors, and this makes a special color error correction possible that cannot be achieved with normal types of optical glass. Glasses with anomalous partial dispersion are used for the enhancement of image quality, and they are used in all Leica binoculars and spotting scopes.

High-Definition optics (HD)/Achromatic color aberration correction (APO) The optics on the new Ultravid and Televid HD models stand apart from conventional optics by way of their increased image resolution performance. The contrast on these models is greater, color aberrations are reduced, the image looks sharper, details are more clearly recognizable, and the color reproduction of the image is extremely natural. This is made possible by optimizing the existing optical systems with the help of new FL lenses. Here, FL denotes a special type of lens made from calcium fluorite – a crystalline mineral with an extremely low refractive index and very low dispersion (see “color aberration”). Furthermore, these optical glasses offer an impressively high degree of transmission – from UV right into the IR segment of light. By combining FL types of glass with “normal” optical glasses and glasses with anomalous partial dispersion to form achromatic optical systems, chromatic aberration and other imaging errors can be significantly reduced. This performance is only further improved by apochromatic aberration correction (APO), as used in the APO models. They are also made up of a combination of FL and “normal” optical glasses as well as glasses with anomalous partial dispersion, but are considerably more elaborate, since in their special optical construction they are optimized for three lengths of light waves (primary and secondary spectrum) instead of two (only primary spectrum) – as in achromats. The more compact this kind of optical system has to become, the more complicated its development is. Especially for long focal lengths and high magnifications, this kind of elaborate APO construction is worthwhile, because it ensures a totally impressive viewing experience.

ASPH. ASPH. is an abbreviation that denotes the use of at least one aspherical lens surface in an optical system. Unlike regular spherical lens surfaces, aspherical lenses have a curvature near their edges that is different from the curvature in the center of the lens. That makes it possible to influence light rays passing through the edges of the lens differently from light rays passing through the center portion of the lens. It also makes it possible to achieve several correction goals simultaneously with only one lens element. Furthermore it helps to reduce the weight and the physical size of an optical system and it makes certain imaging characteristics possible to begin with. Such surfaces help to increase the image quality or to influence the distortion. The fabrication and the handling of aspherical lens elements is significantly more costly, however, than that of conventional spherical lenses. In order to assure the extremely high image quality in all models of Ultravid binoculars, aspherical lenses are used effectively in the 25 mm and 20 mm BR/BL models. In the remaining models the high image quality is achieved by means of complex optical systems that consist of several lens elements.

Glossary

Light transmission, the degree of same When light rays strike on glass surface, only some of them penetrate the glass, the others are reflected. The more light penetrates a lens element or an optical system, the higher is their transmission. As a rule, there is an approximate 4 % light reflection at every glass-/air surface of an uncoated lens. This effect increases exponentially the more lens elements there are in an optical system (in Leica binoculars there are up to 11 optical elements = 22 glass-/air surfaces).

Lens without coating

100 % light

approx. 8 % reflection
(4 % glass-air surface)

92 % transmission

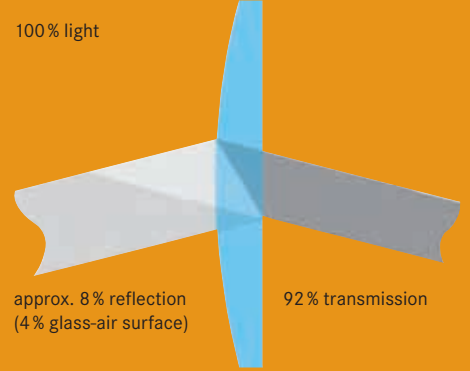

Coatings In order to minimize the reflection of light rays, complex procedures are employed, involving the vapor deposition in high vacuum of numerous layers of exceedingly thin layers of approximately 0.000125 millimeters, which corresponds to 1/500 of the thickness of a human hair. At Leica, high-performance broadband coatings are applied that are tailored specifically to the types of glass that are being used. Not only do they have the task of elevating the transmission of an optical system to a close as possible to 100 %, they also have the important task whenever possible to protect the particularly exposed external lens surfaces from environmental influences and from damages such as scratches. These two requirements – high transmission and high environmental- and scratch resistance – are combined in the innovative multi-layer coating LEICA HDC™.

Lens with Leica HDC™ multi layer coating

100 % light

approx. 0,3 % reflection
(0,15 % glass-air surface)

99,7 % transmission

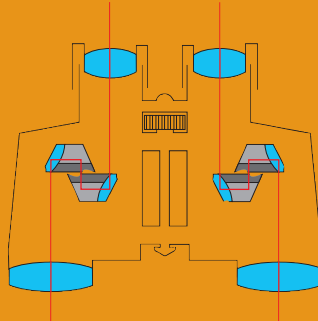
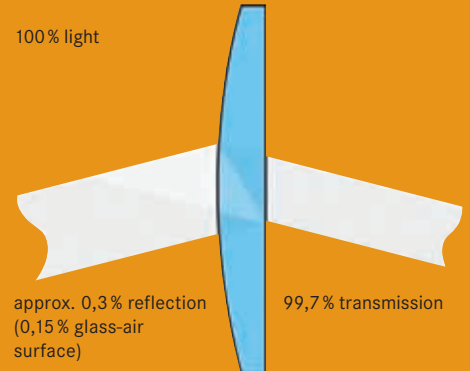

Prism systems Prisms have the task of bringing inverted and laterally reversed images of an object back into the right position (which is why they are also called reversing systems). The prisms used in such systems have a decisive influence on the construction and the compactness of a binocular. There are two several types of prism systems, such as roof (left) and porro (right).

Phase correction coating P40 The P40 layer on roof prisms has the task of increasing the sharpness of the image and reducing disturbing reflections and stray light. Without a P40 coating on the prisms, light sources are rendered with radiating star effects. With a P40 coating they are reproduced very naturally. In this regard and in direct comparison, the qualitative differences of different optical brands become obvious very quickly.

Mechanical quality

For the requirements of intensive use in nature, high-performance binoculars and spotting scopes must be able to withstand extreme mechanical demands over long periods of time. To that end, the optical and mechanical components are mounted in the body of a Leica binocular or spotting scope in such a way that they cannot shift. The tolerances for the mechanisms used for moving lens groups are set at a very minimum and they are strictly enforced. An important parameter in the selection of the right materials is their extreme longevity, and they must also safeguard the highest degree of precision. Leica meets these requirements with proven and durable materials such as aluminum die-castings and steel. In order to achieve a significant reduction in weight – for instance in the Ultravid models – Leica also employs special high-tech materials such as magnesium and titanium. In the planning of all these aspects, the longevity of the products and the benefits for the customers are always in the forefront.

Focusing In order to focus the binocular or spotting scope on an object, optical groups within them have to be shifted with respect to one another. When focusing is accomplished by moving a lens group inside the instrument, this is referred to as internal focusing. This enclosed construction and the additional nitrogen filling make it possible to design watertight binoculars and spotting scopes that guarantee a uniformly high imaging performance that lasts for the entire life of the instrument, even under the most adverse climatic conditions. The particularly short focusing travel from near to infinity on Leica binoculars (on the Ultravid models it amounts to slightly more than a single turn) the observer can always keep the subject in sharp view very quickly.

Leica innovations and patents

The proficiency for innovations at Leica is demonstrated not least by the countless patented problem solutions that are valued by customers and that evolved in close cooperation and coordination with international innovation teams composed of users in a great variety of fields.

Leica HDC™ (High Durable Coating) HDC™ is the proprietary designation of a rub-proof and transmission-enhancing multi-layer coating process developed by Leica that consists of 7 to 10 exceedingly thin layers, depending on the type of glass to which they are applied. HDC™ signifies high light transmission combined with high resistance to scratches and environmental effects, which translates into brilliant images and durability, even in intensive outdoor use.



Leica HighLux-System HLS™ The HighLux-System HLS™ combines extensive mechanical steps for the reduction of stray light (such as light traps, matte black lacquer, etc.) and an especially developed mirror layer for prisms into an optimally tailored system. The HighLux-System HLS™ is used in Duovid and Ultravid binoculars. The highly reflective dielectric mirror layer consists of 42 extremely thin individual layers that produce a degree of reflection of more than 99.5%. This system makes it possible to increase transmission, contrast and sharpness significantly – the observer gains an extremely bright, natural pictorial impression with neutral color rendition.

Mirror layer of Leica HighLux-System HLS™

Glossary



Multifunction center drive The combination knob for the Leica center drive feature performs two important functions : diopter compensation and focusing. Because of its size, it is always easy to use as a focusing wheel and it provides ergonomic handling and a steady observation. The large diopter scale allows quick and convenient setting of your personal diopter value.

ADC™ (Automatic Diopter Compensation) ADC™ (Automatic Diopter Compensation) is the eminent innovation in Duovid binoculars. ADC™ maintains the original diopter setting when you change the magnification (from 8 x to 12 x, or from 10 x to 15 x as the case may be).

Automatic Diopter Compensation ADC™

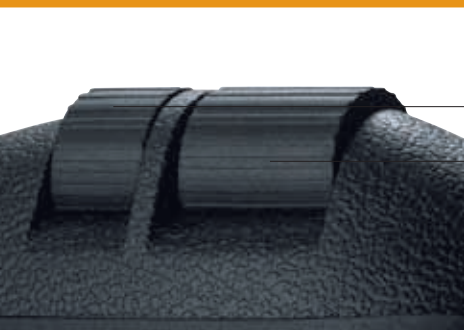

quick initial focusing

fine focusing

Televid dual focusing The dual focusing device patented by Leica is incorporated in Leica spotting scopes. Two separate focusing drums enable the observer to perform a quick initial focusing followed by an accurate fine focusing to obtain an image that is always perfectly sharp.

Removable, sliding eyecups with two click stops A newly designed rotating sliding eyecup is used on binocular models Duovid 50 and 42, Ultravid 50, 42 and 32 and Geovid. It can easily be removed for cleaning at any time and it has two click stops with which different eye relief distances (AP positions) can be set individually (with eyeglasses = retracted ; without eyeglasses = pulled out). With its gently cushioning rubber element it guarantees long, relaxed observation and for eyeglass wearers it provides secure positioning without damaging the eyeglasses. The remaining Leica binoculars are equipped with sliding eyecups that guarantee an optimal eye relief.



LED displays in rangefinders The actively glowing LED displays in Rangemaster-, Pinmaster- and Geovid models employ a sensor that automatically tailors their intensity to the prevailing ambient light at all times. This feature assures perfect legibility in all light conditions and it especially prevents eye glare during nighttime observation.

Leica rangefinder technology – with a press of the button

Leica rangefinders distinguish themselves primarily by the fact that they can be operated intuitively, by the excellent legibility of their LED displays and by their bright optics. Pressing the measuring button just once switches the instrument on, the target sight appears in the display and the object can now be addressed. Pressing the button a second time displays the measured distance. By keeping the button pressed, the instrument automatically switches to a scan mode, which is indicated by a blinking display. The instrument now provides continually updated measurement values. The scan mode is especially helpful for the perfect measurement of distances to small or rapidly moving targets.

The measurement of distances is based on an eye-safe light pulse that is reflected by the object that is being sighted. A microprocessor uses the time elapsed until the light pulse has returned to compute the distance and then indicates it in the instrument's display.

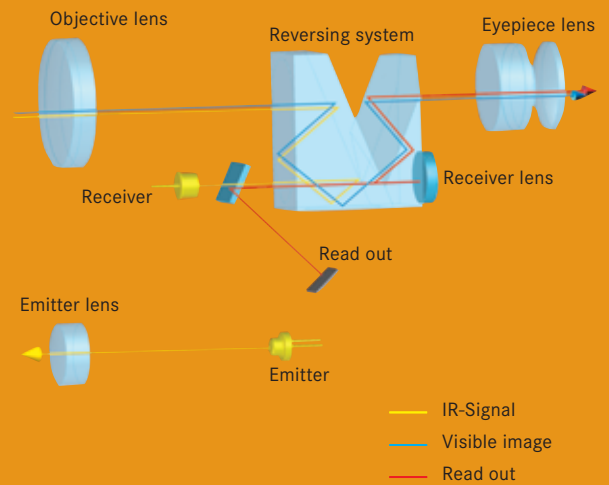



3 See more

4 New ideas for even better visibility

8 100 years Leica binoculars

13 Experience Nature / Observe and preserve

17 The Duovid class 20 LEICA DUOVID 10 +15x50 / 21 LEICA DUOVID 8 +12x42

22 The Duovid class : Key features at a glance

25 The Ultravid class 28 LEICA ULTRAVID HD 50 series / 29 LEICA ULTRAVID HD 42 series /

30 LEICA ULTRAVID BL 42 series / 31 LEICA ULTRAVID HD 32 series / 32 LEICA ULTRAVID BR 25 series /

33 LEICA ULTRAVID BL 25 series / 34 LEICA ULTRAVID BR 20 series / 35 LEICA ULTRAVID BL 20 series

36 The Ultravid class : Key features at a glance

41 The Trinovid class 44 LEICA TRINOVID BCA 25er / 45 LEICA TRINOVID BCA 20er

46 The Trinovid class : Key features at a glance

49 The Televid class 52 LEICA TELEVID HD 82 series / 53 LEICA APO-TELEVID 82 series /

54 LEICA TELEVID HD 65 series / 55 LEICA APO-TELEVID 65 series

56 The new Televid class : Key features at a glance

58 Leica Digiscoping

61 The Geovid class 64 LEICA GEOVID BRF 56 series / 65 LEICA GEOVID BRF 42 series

66 The Geovid class : Key features at a glance

69 The Rangemaster class 72 LEICA RANGEMASTER CRF 1200 / 73 LEICA RANGEMASTER CRF 900

74 The Rangemaster class : Key features at a glance

77 Technical Data

88 Very useful binocular equipment

91 Glossary

Barbary Falcon (Falco pelegrinoides), adult female –
photographed by Dick Forsman in Israel, Dead Sea, March 2007

Cape Teal / Anas capensis



leica-camera.com

In all Leica product areas the focus falls on man and his perceptions. The range on offer is rounded off by numerous cultural activities, photography competitions, trips and seminars as well as technical Customer Service. Further information is available on the Internet or from your specialist dealer.



Leica M system Professional combined viewfinder/rangefinder system that concentrates on photographically relevant functions – with no-compromise optical and mechanical quality. Photographers who want to give free rein to their creativity can choose between 18 fast and compact high-performance lenses as well as two analog and one digital camera model. Ideal for the different sectors of photojournalism, available-light and author photography.



Leica R system Together with the high-performance lenses and the LEICA DIGITAL-MODUL-R, the single-lens reflex camera LEICA R9 is the world's first 35 mm camera system that can be used for analog or digital capture. It is an intuitive and expandable system that retains its value, delivers top-quality pictures and offers creative freedom.



Leica D system Brand-new but still classic : The Leica D system combines state-of-the-art technology with a unique use of forms and intuitive photographic handling from Leica. The LEICA DIGILUX 3 forms the basis for the D system, the first single-lens reflex system from Leica solely geared to digital photography.



Leica compact cameras Leica's handy compact cameras in the C-Lux, D-Lux and V-Lux ranges impress users with their optical performance, user-friendliness and clear lines. Modern digital technology and the tried and tested concepts underpinning analog photography are a winning combination.



Leica Projectors Leica Pradovit projectors are the logical solution for high-quality slide presentation. With their unsurpassed definition and impressive detail rendering they are sure to satisfy the discerning user.



Leica Binoculars and Rangefinders The high performance optical tools produced by Leica for nature watching and hunting are designed to enhance the user's natural powers of perception in even the toughest conditions. The innovative binoculars and rangefinders from Leica are the ideal companions for even the most demanding professionals.



Leica Spotting Scopes Leica's high performance spotting scopes bring faraway objects or extremely fine details breathtakingly close in images of vivid contrast and true-to-life color. Eight models in different and a wide choice of interchangeable eyepieces plus innovative digiscoping solutions cater for the needs of every user.

Black-winged Stilt /
Himantopus himantopus

Leica Trademark of the Leica Camera Group / "Leica" and product names = ® Registered trademarks / © 2007 Leica Camera AG / All rights to change construction, design and range reserved / Concept and Design : Heine/Lenz/Zizka, Frankfurt am Main / Image indication : Product photography : Tom Vack, Alexander Göhr / Nature photography : Franz Bagyi, Boris Bender, Uwe Binhack, Jeff Bouton, Luis Castañeda, Dick Forsman, Uli Hintner, Hermann Netz, Oliver Richter (Leica Akademie), Norbert Rosing, Wolfgang FF Sekker, Sven Sturm, Max Eicke, Steve Dudley
Brochure order number : German 91348, English 91349, French 91350, Italian 91351, Spanish 91352