

Leica Geosystems
Original Accessories
The right selection

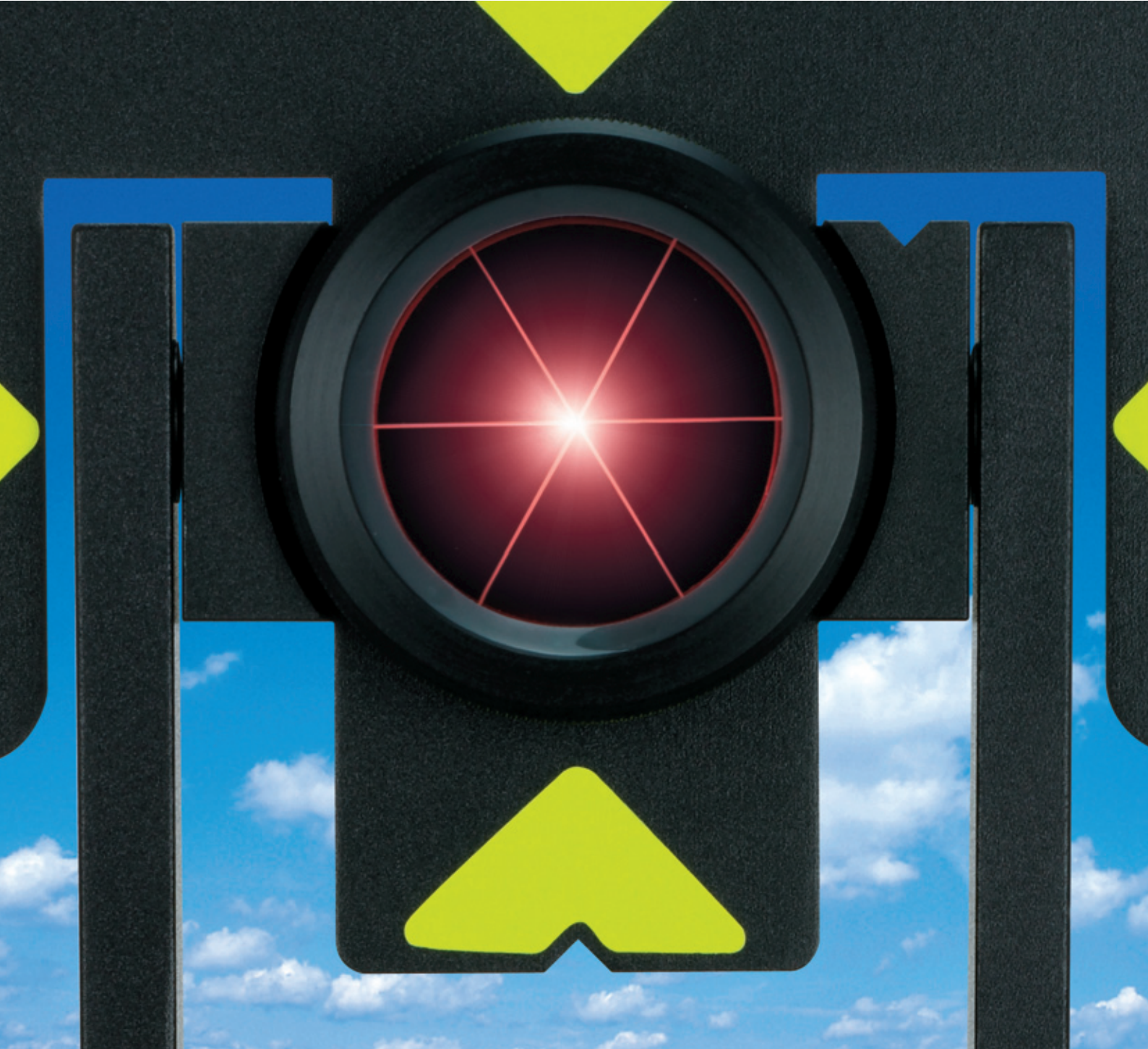

- when it has to be **right**

Leica
Geosystems

Original Accessories Become the best surveyor with Leica Geosystems equipment

Designed and built to the most stringent standards, Leica Geosystems instruments are of the highest quality, extremely reliable and designed to stand up to harsh environments. Original Accessories from Leica Geosystems, meet these same stringent standards. Our engineers design every accessory to perfectly integrate with your instrument so you always achieve the required performance and accuracy.



Quality & Reliability

Leica Geosystems accessories are known for their robustness and dependability in the field because they provide the best reliability over many years, even in extreme environments. The accessories are tested according to Leica Geosystems exacting standards for quality, accuracy and longevity.

Your benefit – Leica Geosystems Original Accessories provide you with the feeling of confidence you are used to getting from your instrument.

Replacement guaranteed

We are so sure of our quality that we replace any Original Accessory with a new, identical product if it fails during the warranty period.

One year warranty

The warranty period for all Leica Geosystems accessories is one year, except for batteries.

With accessories out of warranty, our worldwide service centres are mostly able to repair your product cost-effectively with a wide range of spare parts being available.



The right selection

Original Accessories

To easily select the most suitable accessory to perform your survey task, Leica Geosystems divides its accessories into three distinctive price/performance groups.

	Professional	Basic	Choice
Price/ Performance	Ultimate performance products meeting the highest demands.	Quality products for standard accuracy requirements.	Products with focus on price, for simple surveying applications.
Accuracy	Built to the highest tolerances to achieve the best possible measurement accuracy. ★★ ★	For requirements where a 3 mm positioning accuracy is sufficient. ★ ★	For requirements where a 10 mm positioning accuracy is sufficient. ★
Environmental Specifications	For use even in extreme environments, from -20° C (-4° F) to 50° C (122° F). ★★ ★	For use even in extreme environments, from -20° C (-4° F) to 50° C (122° F). ★★ ★	Should only be used in normal environments, from 0° C (32° F) to 50° C (122° F). ★ ★
Spare Parts	Complete range of spare parts for repairs are available. These remain available for up to 5 years after product phase-out. ★★ ★	Limited spare parts and repairs are offered. These remain available for up to 5 years after product phase-out. ★ ★	No spare parts or repairs are offered for these products. The product will be replaced if failure occurs during the warranty period. ★



The right tripod

Accuracy starts from the ground up

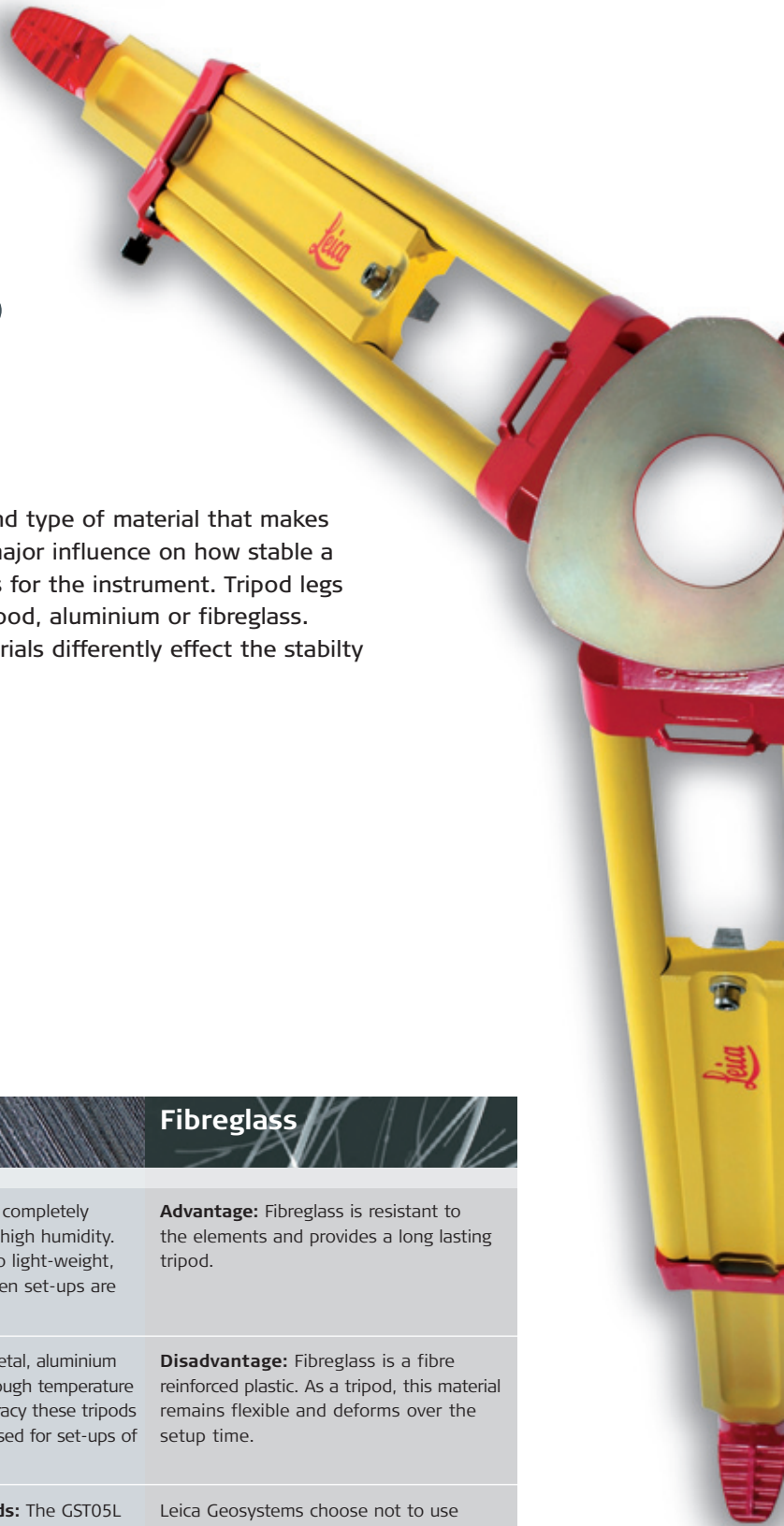

The construction and type of material that makes up a tripod has a major influence on how stable a platform it provides for the instrument. Tripod legs consist either of wood, aluminium or fibreglass. Each of these materials differently effect the stability of the tripod.

Wood	Aluminium	Fibreglass
<p>Advantage: Of all materials, wood is the most stable and less susceptible to expansion when exposed to the warming effects of the sun. Wooden tripods also have excellent vibration damping characteristics.</p>	<p>Advantage: Aluminium is completely resistant to conditions of high humidity. Aluminium tripods are also light-weight, providing convenience when set-ups are often changed.</p>	<p>Advantage: Fibreglass is resistant to the elements and provides a long lasting tripod.</p>
<p>Disadvantage: Wood is porous and absorbs water which causes it to deform. It is therefore vital that the wood be completely sealed.</p>	<p>Disadvantage: Being a metal, aluminium expands and contracts through temperature changes. To maintain accuracy these tripods should therefore only be used for set-ups of short duration.</p>	<p>Disadvantage: Fibreglass is a fibre reinforced plastic. As a tripod, this material remains flexible and deforms over the setup time.</p>
<p>Leica Geosystems tripods: The GST20 range of tripods are sealed with several layers of oil and paint and the GST05 is covered with a water-tight plastic wrap for complete protection.</p>	<p>Leica Geosystems tripods: The GST05L and CTP103 aluminium tripods are resistant to the elements and provide for long life in all environmental conditions.</p>	<p>Leica Geosystems choose not to use fibreglass for surveying tripods. We do not consider them suitable to achieve reliable measurements with our modern motorized instruments.</p>

The stability of tripods is primarily defined by their vertical movement and horizontal drift over time. The effect of different tripod materials can be clearly seen in the graphs. In both cases, the wooden tripods remain the most stable over the set-up time.

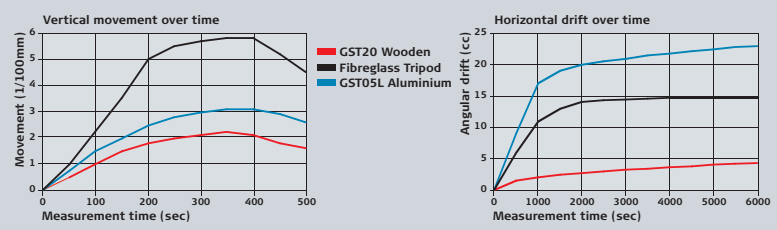

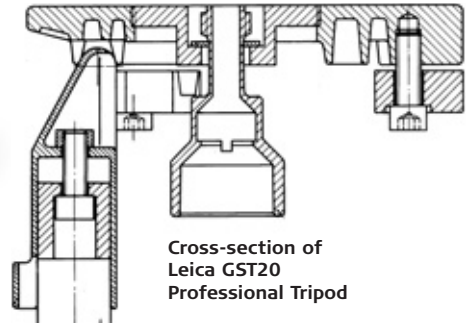

Cross-section of
Leica GST20
Professional Tripod



Quality counts

Leica Geosystems tripods are the industry leaders for over 80 years. Their design and materials are constantly being optimised. Using high quality components, these tripods provide a long life in all environments.

The right stand

Original tripods

Leica Geosystems offers a range of extremely stable and long lasting tripods to suit all instruments and surveying applications. In order to achieve the instrument specified accuracy it is vital that the correct tripod is selected.

Professional	Basic	Choice
GST20 Range	GST05 Range	CTP Range
<ul style="list-style-type: none"> ■ The GST20 range of wooden tripods provide the highest stability over long periods. ■ Required when a maximum angular accuracy is required. ■ Strongly recommended for use with motorized instruments. 	<ul style="list-style-type: none"> ■ The GST05 wooden tripod is recommended for all manual TPS of 5" or less. ■ The GST05L aluminium tripod is suitable for prism stations and levels. ■ Ideal for temporary GPS reference stations. 	<ul style="list-style-type: none"> ■ The CTP101 wooden and CTP103 aluminium tripods are low cost alternatives to the GST ranges. ■ Extremely rugged and therefore suitable for everyday construction surveys. 

The right prism

For maximum accuracy and maximum range

Various aspects define the achievable measurement precision and distance range of prisms. The most significant of these are Reflective Coating, the Angular Beam Deviation and Anti-reflex Coating.

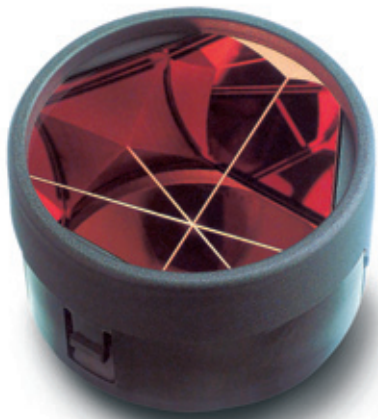

Reflective Coating

Leica Geosystems prisms have a copper coating on the reflection surfaces. Copper offers a very high reflectance of infrared beams. Being robust and resistant to corrosion, the coating has a long useable life.

Without a reflective coating, the distance measuring, ATR and PowerSearch range reduces by over 30%. In addition, incorrect measurements can result when moisture forms droplets on the reflecting surface.

Angular Beam Deviation

The precision to which the prism glass is cut is measured in terms of the Angular Beam Deviation. This is the angular difference between the entering and exiting measurement beam. The higher this deviation, the weaker the returned signal strength to the EDM and hence the shorter the measuring range.

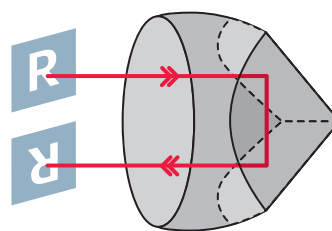

Anti-reflex Coating

The front surface of most Leica Geosystems prisms have an anti-reflection coating. Without this, the front face of a prism reflects part of the EDM signal. At close ranges, this causes incorrect distance measurements. The coating is optimised for the frequency of the Leica Geosystems distance measuring signal. Therefore other brands of coated prisms still partially reflect and can cause incorrect measurements.

An additional feature of the coating is that it is remarkably hard and therefore protects the surface from scratches.



Quality counts

Leica Geosystems reflectors are produced to the highest possible accuracy. After manufacture, the reflecting surface of each prism is measured by Interferometer to determine its Angular Beam Deviation. Only those prisms meeting the required specifications are supplied to the market.

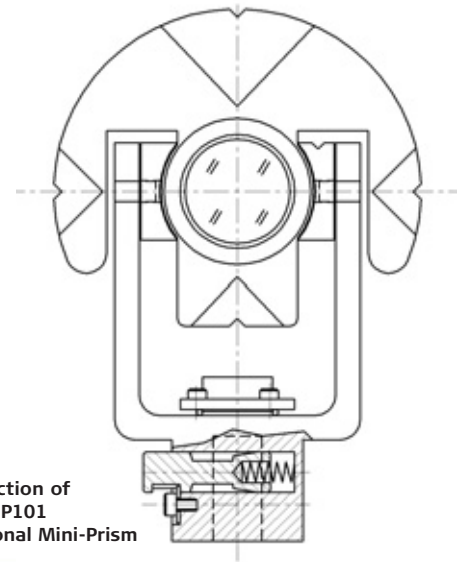



Cross-section of
Leica GMP101
Professional Mini-Prism

The right target

Original prisms

Leica Geosystems prisms use the highest quality glass and are improved with optical coatings to achieve the longest possible measuring range at the highest accuracy. Round prisms are available in 62 mm diameter for maximum range or as a convenient 24 mm diameter mini-prism.

Professional	Basic	Choice
GPR121, GMP101	GPR111, GMP111	CPR105
<ul style="list-style-type: none">■ Mounted in metal holders for the best centring accuracy, stability and longevity.■ The Beam Deviation of the GPR121 is less than 2" and for the GMP101 is less than 6".■ Ideal for precision and long range distance measurement.	<ul style="list-style-type: none">■ Mounted in Polymer holders which are unaffected by the elements, even when exposed for long periods.■ The GPR111 has a Beam Deviation of less than 8".■ These light-weight prisms provide sufficient accuracy for normal surveying applications.	<ul style="list-style-type: none">■ The CPR105 patented Flat Prism provides two back-to-back reflectors, both having 0-constants.■ The unique Cat-eye reflector provides a RL measurement range of 250 m.■ Ideal for traversing, since the prism can be measured from both sides without requiring rotation.
		

The right tribrach

For accurate positioning over the surveying point

The stability of the tripod and tribrach is the primary influence on the accuracy of measurements and therefore it is important to use reliable and stable equipment.

Perfectly suited to your instrument

Leica Geosystems tribrachs are designed to operate reliably even in extreme temperatures, humidity and dusty conditions. In all situations, the maintenance-free foot screws ensure a movement that is always smooth and free of play.

The support area of the tribrach is matched precisely to the base circumference of Leica Geosystems equipment. This provides extremely accurate forced centring.

The optical plummet is of a robust construction, which virtually eliminates the need for adjustment during the lifetime of the tribrach. For tribrachs without optical plummet the innovative SNLL121 laser plummet provides for a convenient and rapid setup.



Torsional Stiffness

The top plate of the tribrach moves relative to the base plate when the mounted instrument is rotated. This force is most pronounced in motorised instruments, due to high acceleration and deceleration.

The accuracy with which the tribrach returns to its original position, once the instrument has stopped rotating, is known as hysteresis. Since the hysteresis of the tribrach has a direct influence on the angular accuracy of the instrument, choosing the correct tribrach is important.



Quality counts

The foot screw assembly is of the highest quality, providing an extremely stable support plate. After production, each tribrach is laboriously measured to determine its hysteresis. Only those tribrachs that are within specifications are supplied by Leica Geosystems.

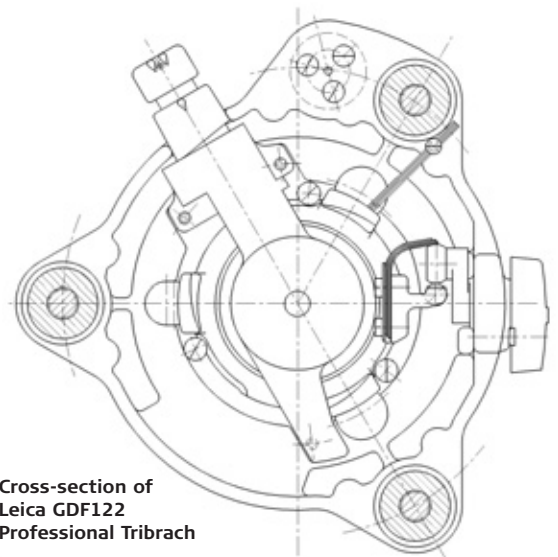

Cross-section of
Leica GDF122
Professional Tribrach

The right set-up

Original tribrachs

Leica Geosystems offers a range of tribrachs to suit all accuracy requirements. The correct tribrach should be chosen to meet the requirements of the surveying application.

Professional	Basic	Choice
GDF121/GDF122	GDF111/GDF112	CTB101
<ul style="list-style-type: none"> ■ The hysteresis of the Professional tribrachs is guaranteed to a maximum of 1" (3 cc). ■ The foot screws are maintenance free, ensuring a movement that is always smooth and free-of-play, in all environmental conditions. ■ These tribrachs should be used with all applications where the required accuracy exceeds 3". 	<ul style="list-style-type: none"> ■ The Basic series tribrachs have a hysteresis to a maximum of 3" (10 cc). ■ The foot screws have a large diameter which permits fine adjustment even when wearing work gloves. ■ The GDF112 with optical plummet is ideal for GPS antennas and prism stations. 	<ul style="list-style-type: none"> ■ The CTB101 tribrach has a hysteresis to a maximum of 5" (15 cc). ■ The CTB101 is a low-cost tribrach which is suitable for use in normal environments. ■ It is the standard tribrach supplied with the Builder TPS and is suitable for light-weight instruments.
		

The right communication tools

Secure data for peace of mind

Losing data after a day's work is extremely frustrating and expensive. Leica Geosystems storage media and communication products are of the highest quality in order to achieve continuous reliability.

The right data

Compact Flash (CF) cards

Leica Geosystems memory cards are perfectly suited to the requirements of System 1200 sensors. These instruments operate differently to consumer devices which read or write individual files. The TPS or GPS creates a database on the card and constantly switches between different open files. A standard CF-card controller software is unable to perform this required multi-tasking and may cause communication problems with System 1200 instruments.



One of the primary causes of data loss is when a card is subject to shock, which can occur as a result of being dropped. The ruggedised industrial cards are rated to withstand up to a 3 metre drop to hard ground. In addition, these cards will operate reliably even in extreme temperatures and high humidity conditions.



Data cables

Most instruments have a data port for communication by cable. Connection to the external device can be made to a RS232 or USB port by using the appropriate cable. Cables provide extremely secure data transfer to and from the instrument. The highest specified wire and plugs are used which remain reliable even in extreme heat or cold.

Bluetooth® Wireless Technology

A **Bluetooth®** module can be integrated into the housing of the TPS1200 by local service centres.

An external **Bluetooth®** Kit (Art.No.8216666) is available which connects to all Leica Geosystems instruments. With this set-up, data can be transferred to or from any external device which has **Bluetooth®** wireless technology within a range of 100m. The module is pre-programmed to be plug-and-play compatible.



Technical specifications

Professional

Basic

Choice

	Professional	Basic	Choice	Material	Max. Height	Min. Height	Weight
Tripods	296632 GST20			Wood	180 cm	107 cm	6.40 kg
	328422 GST40			Wood	170 cm	170 cm	6.00 kg
		399244 GST05		Wood	176 cm	107 cm	5.60 kg
		563630 GST05L		Aluminium	176 cm	107 cm	4.60 kg
			726831 CTP101	Wood	166 cm	104 cm	5.70 kg
			726833 CTP103	Aluminium	167 cm	103 cm	4.50 kg
	Professional	Basic	Choice	Hystersis	Colour	Opt. Plummet	Weight
Tribrachs	667304 GDF121			1" (3cc)	Pale Green	No	780 grams
	667307 GDF122			1" (3cc)	Pale Green	2x magnific.	860 grams
		748888 GDF111-1		3" (10cc)	Pale Green	No	780 grams
		667308 GDF112		3" (10cc)	Pale Green/Red	2x magnific	670 grams
			726839 CTB101	5" (15cc)	Black	No	780 grams
	Professional	Basic	Choice	Centring Acc.	Plummet	Plate level	Rotable
Carriers	360532 GZR2			0.3mm	No	2" / 2mm	No
	428340 GZR3			0.3mm	0.5mm / 1.5m	2" / 2mm	Yes
	667316 SNLL121			0.3mm	1.0mm / 1.5m	2" / 2mm	Yes
	667313 GRT144			1mm	No	No	No
		725566 GZR103		1mm	0.5mm / 1.5m	2" / 2mm	Yes
	Professional	Basic	Choice	Centring Acc.	Ang. Beam Dev.	Anti-reflex Coating	Target Plate
Standard Prisms	555631 GPH1P			0.3 mm	2"	No (Tilted)	No
	641617 GPR121			1.0 mm	2"	Yes	Attached
	362830 GPR1 with GPH1			1.0 mm	2"	Yes	362823 GZT4
	639985 GRZ4			2.0 mm	6"	Yes	No
	754384 GRZ122			2.0 mm	6"	Yes	No
		641618 GPR111		2.0 mm	8"	No	Attached
		753492 GPR113		2.0 mm	8"	No	362823 GZT4
		726295 GPR112		n / a	6"	No	No
			731346 CPR105	2.0 mm	n/a	No	Attached
	Professional	Basic	Choice	Centring Acc.	Ang. Beam Dev.	Anti-reflex Coating	Target Plate
Mini Prisms	641662 GMP101			1.0 mm	6"	Yes	Attached
		641615 GMP111		2.0 mm	6"	Yes	Attached
		642534 GMP111-0		2.0 mm	6"	Yes	Attached
		641762 GMP104		n / a	6"	No	No
		644327 GRZ101		2.0 mm	6"	Yes	No
	Professional	Basic	Choice	Weight	Max. Height	Min. Height	Bubble Sensitivity
Telescopic Poles	385500 GLS11			0.94 kg	2.15 m	1.24 m	8'
	754391 GLS12			0.95 kg	2.00 m	1.39 m	8'
	667309 GLS111			1.48 kg	2.60 m	1.40 m	45'
	667310 GLS112			1.88 kg	3.60 m	1.47 m	45'
	752292 GLS30			0.75 kg	2.00 m	1.36 m	20'
			748967 CPP105	1.32 kg	2.00 m	1.28 m	15'

Batteries

For specifications of batteries and chargers, refer to the separate brochure Chargers & Batteries (Art.No.722797)

Whether you want to monitor a bridge or a volcano, survey a skyscraper or a tunnel, stake out a construction site or perform control measurements – you need reliable equipment. Using Leica Geosystems Original Accessories ensures the specifications of instruments are met, giving you the precise and reliable measurements that you need and expect. With Leica Geosystems Original Accessories you can rely on accuracy, quality and long life, and guarantee that you get the most from your instrument.

When it has to be right.

Illustrations, descriptions and technical specifications are not binding and may change.
 Printed in Switzerland – Copyright Leica Geosystems AG, Heerbrugg, Switzerland, 2006.
 755693en – XI.06 – RDV



**Total Quality Management –
 Our commitment to total
 customer satisfaction**

Ask your local Leica Geosystems dealer for more information about our TQM program.

Laser plummet:

Laser class II in accordance with FDA 21CFR Ch.I § 1040

The **Bluetooth®** word mark and logos are owned by Bluetooth SIG, Inc. and any use of such marks by Leica Geosystems AG is under license. Other trademarks and trade names are those of their respective owners.



**Leica Geosystems
 Accessories**
 Equipment List



**Chargers &
 Batteries**
 Product brochure



The Catalogue
 Product Instruments
 and Accessories for
 Construction